

CRABI 12 and 18 Month Old User Manual





For information on Humanetics products, please visit our web site at www.humaneticsatd.com
or contact:

Humanetics Innovative Solutions
47460 Galleon Drive
Plymouth, MI 48170, USA
Telephone: 734-451-7878
Fax: 734-451-9549

No part of this publication may be reproduced, stored in a retrieval system or transmitted in any form or by any means, electronic, photocopying, recording, mechanical or otherwise, without the express written consent of Humanetics Innovative Solutions.

Copyright © 2015 Humanetics Innovative Solutions, All rights reserved.

The information in this manual is furnished for informational use only, and is subject to change without notice. Humanetics Innovative Solutions assumes no responsibility or liability for any errors or inaccuracies that may appear in this manual.

Notice: This product may contain lead

A list of components that may contain lead is being maintained on the Humanetics web site. The list, organized by dummy type, shows subcomponents that may currently or in the past have contained lead or a lead based alloy. Please refer to the Humanetics web site under ATD Lead Disclosure for information regarding lead in this product. http://www.humaneticsatd.com/Lead_Disclosure

Table of Contents

Section 1. Introduction.....	6
1.1 Foreword	6
1.2 Fastener Designations	6
1.3 Construction and Configuration.....	8
1.3.1 General.....	8
1.3.2 Head.....	8
1.3.3 Neck	8
1.3.4 Torso	8
1.3.5 Limbs.....	8
1.4 Clothing	9
1.5 Instrumentation.....	10
1.6 Accelerometer Usage.....	11
Section 2. Disassembly Procedures	13
2.1 Head Assembly	13
2.2 Limbs and Torso Flesh.....	13
2.3 Neck and Torso.....	17
2.3.1 Twelve-Month-Old.....	17
2.3.2 Eighteen-Month-Old	21
2.4 Damage Inspection	26
2.4.1 General Inspection	26
2.4.2 Head.....	26
2.4.3 Neck	26
2.4.4 Upper/Lower Torso.....	26
2.4.5 Shoulder	26
2.4.6 Hip	27
2.4.7 Limbs (all).....	27
Section 3. Assembly Procedures	28
3.1 General Information	28
3.2 Instrumentation Cable Routing.....	28
3.3 Neck and Torso.....	28
3.3.1 Twelve Month Old	29
3.3.2 Eighteen Month Old	29
3.3.3 Twelve and Eighteen Month Old.....	29
3.3.4 Twelve Month Old	30

3.3.5	Eighteen Month Old	30
3.3.6	Twelve and Eighteen Month Old	30
3.4	Torso Flesh and Head	31
3.5	Limbs	32
Section 4.	Calibration Test Procedures	33
4.1	Head Drop Test	33
4.2	Neck Tests	36
4.3	Thorax Impact Test	43
Section 5.	Inspection Test Procedures	45
5.1	External Dimensions	45
5.2	Mass Measurements	48
Section 6.	Appendices	50
6.1	Appendix A	50
6.1.1	General	50
6.1.2	Preliminary Check-Out	50
6.1.3	Installation	51
6.1.4	Recalibration	51
6.1.5	Cleaning	52
6.2	Appendix B, Guidelines for Maintenance of Molded Parts	52
6.2.1	Flesh Repairs	52
6.2.2	Storage of Rubber Parts	52
6.3	Appendix C, Joint Adjustment Procedure	52
6.3.1	Hands and Arms	53
6.3.2	Legs and Feet	53
6.4	Appendix D, Drawings	53
6.5	Appendix E, Head CG	65

Table of Figures

Figure 1.	CRABI 12 and 18 Month Old Dummies	7
Figure 2.	CRABI 12 Month Old Clothing	9
Figure 3.	Instrumentation Locations	12
Figure 4.	Exploded View, Head Assembly	14
Figure 5.	Exploded View, Limb Assembly	16
Figure 6.	Removal of torso flesh, abdomen and chest foam (12 and 18 mo.)	18
Figure 7.	Exploded View, Torso and Neck (12 mo.)	20
Figure 8.	Exploded View, Torso and Neck (18 mo.)	23
Figure 9.	Exploded View, Neck and Lumbar	25
Figure 10.	Cable routing rear view	31
Figure 11.	Head Drop Test Setup (Frontal Impact)	35
Figure 12.	Head Drop Test Setup (Rear Impact)	36
Figure 13.	Neck Pendulum Arm Specifications	40
Figure 14.	Neck Flexion Test Set-up	41
Figure 15.	Neck Extension Test Set-up.....	42
Figure 16.	Thorax Impact Set-Up	44
Figure 17.	External Dimensions Set-up.....	48

Section 1. Introduction

1.1 Foreword

In September of 1990 the Society of Automotive Engineers (SAE) Child Restraint Air Bag Interaction (CRABI) Task Force requested that the Mechanical Human Simulation Subcommittee of the Human Biomechanics and Simulation Standards Committee (HBSSC) address the need for a new infant dummy. Since existing infant dummies allowed for no instrumentation or very limited instrumentation options it was agreed that a new infant test dummy was necessary and an Infant Dummy Task Force was formed to begin the project. A prototype version of the six-month old Child Restraint and Air Bag Interaction (CRABI) dummy was produced first in Fall of 1991. Prototype versions of the twelve- and eighteen-month old CRABI dummies were produced and evaluated in 1993/1994. Limited biomechanical data were available as a basis for the dummies. A 1997 Paper, SAE Paper # 973317, "Biomechanical Basis for the CRABI and Hybrid III Child Dummies", by A. Irwin and H.J. Mertz, became the basis for the redesign of the head and neck in 1998 by the Hybrid III Dummy Family Task Group which continued the earlier design work of the Infant Dummy Task Force. The twelve- and eighteen-month-old infant CRABI dummies, Figure 1, were designed for use with forward and rearward facing child restraints. They may also be used for lateral impact tests. The two dummies are very similar with several components being interchangeable. The eighteen-month old differs from the twelve-month-old in that it has neck and torso adaptors to provide the correct standing, seated and shoulder heights. The torso flesh is larger and the upper and lower arm and leg assemblies are longer. Some of the components, on each of the dummies, can be installed upside down and/or backwards. Extreme care should be taken when assembling and/or replacing components to ensure they are installed correctly.

1.2 Fastener Designations

Threaded Fastener Abbreviations Used in Manual:

- SHCSSocket Head Cap Screw
- FHCSFlat head Cap Screw
- BHCSButton Head Cap Screw
- SHSSSocket Head Shoulder Screw
- SSCPSocket Screw, Cup Point

All fastener dimensions given in this manual are in the English system.



Figure 1. CRABI 12 and 18 Month Old Dummies

1.3 Construction and Configuration

1.3.1 General

Biomechanical response targets were specified for head impact, neck flexion and neck extension by scaling the corresponding requirements of the mid-size adult male that are specified for the Hybrid III 50th percentile ATD, taking into account the effects of differences in size, geometry, mass and tissue properties between infant and adults (SAE paper #973317, “Biomechanical Basis for the CRABI and Hybrid III Child Dummies”, A. Irwin and H. J. Mertz).

1.3.2 Head

The skull is manufactured from fiberglass with a steel weldment insert. The skin is molded urethane. An upper neck load cell with six channels (or its simulator) is assembled with the head to allow for installation of a triaxial configuration of uniaxial accelerometers at the center of gravity (CG). A separate accelerometer can be installed at the rear of the accelerometer mount to measure angular acceleration in the sagittal plane.

1.3.3 Neck

A flexible, molded rubber neck is used to give the head assembly human-like flexion and extension characteristics. A six-channel load cell can be mounted at both the upper and lower ends of the neck assembly.

1.3.4 Torso

Chest foam and a chest foam support assembly mounted on a thoracic spine box make up the chest section. The shoulders are made of flexible rubber joints. A two-channel load cell can be mounted in each shoulder to measure X- and Z-axis loading. The thoracic spine is a welded aluminum structure that provides a mounting location for the triaxial configured accelerometers at the “T1” vertebrae. The pelvis/lumbar assembly includes a welded aluminum pelvis structure and a flexible molded rubber spine with a mounting configuration for a six-channel load cell between the base of the lumbar spine and the top of the pelvis. The pelvis aluminum structure also provides space for triaxial configured accelerometers which are mounted at the bottom of the lumbar load cell (or simulator) and space for an optional pubic load cell to measure X- and Z- axis loading. An abdominal insert is made of open cell urethane foam. The torso flesh is molded urethane with nylon netting reinforcement.

1.3.5 Limbs

The limbs are molded urethane around an aluminum or plastic “bone” structure. The hip joint is a flexible rubber joint like the shoulder. The elbow and knee joints have stops to provide the correct range of motion. (Not available in eighteen-month-old as of publication.)

1.4 Clothing

Twelve-Month-Old – The clothing recommended for use with the dummy consists of a sweatshirt, size twelve (12) months, Part No. 6000019, and sweatpants, size twelve (12) months, Part No. 6000026. The material is 50% cotton and 50% polyester. Shoes are not required. Clothing mass should not exceed 0.25 kg (.55lb).

Eighteen-Month-Old – The clothing recommended for use with the dummy consists of a sweatshirt, size eighteen (18) months, Part No. 6000027 and sweat pants, size eighteen (18) months, Part No. 6000028. The material is 50% cotton and 50% polyester. Shoes are not required. Clothing mass should not exceed 0.25 kg (.55lb).

The clothing described in the above paragraphs is shown in Figure 2.



Figure 2. CRABI 12 Month Old Clothing

Size	Torque (in-lb)	Torque (N·m)
0-80	1.00	0.113
2-56	2.5	0.283
4-40	12.0	1.36
6-32	23.0	2.60
8-32	41.0	4.63
10-24	60.0	6.78
10-32	68.0	7.68
¼-20	144	16.3
¼-28	168	19.0
5/16-18	300	33.9
5/16-24	300	33.9
3/8-16	540	61.0
3/8-24	600	67.8

Table 1. Torque Specifications

Notes:

1. This applies to clean and dry parts. A lubricated screw requires less torque (15% to 25% less) to attain the same clamping force as a non-lubricated screw.
2. The references for this specification are Smith Fastener Company, Brake Products Inc., and C & J Fastener Inc.

1.5 Instrumentation

Available Instrumentation. The SAE Task Group agreed on a list of instrumentation which could be useful to evaluate child restraints and airbag interactions with children of this size. The twelve- and eighteen-month-old CRABI dummies were designed to accommodate any of the following instruments:

See Figure 3.

- Three uniaxial accelerometers in the head at the center of gravity
- A fourth uniaxial head acceleration (Z-axis) for rotational analysis
- Six-channel upper neck load cell
- Six-channel lower neck load cell
- Triaxial accelerometers in the upper torso
- Triaxial accelerometers in the pelvis

- Six-channel lumbar spine load cell
- Two-channel shoulder load cell for each shoulder
- Two-channel pubic symphysis load cell

Note: the same load cell can be used in the upper neck, the lower neck and the lower spine locations. When installed correctly be aware the Fx and Mx channel polarities will be opposite for the upper neck orientation compared to the lower neck and spine orientations. Lower neck and spine have the same orientation.

1.6 Accelerometer Usage

The accelerometer mounts presented in this manual are designed for use with NHTSA's SA572-S4 accelerometers. Other types of accelerometers and/or mounts may be obtained and used as long as the seismic mass locations are within nominal tolerance limits (reference CFR 49 Part 572), the mass of the head assembly with accelerometers and mount is within the specified tolerance, and the accelerometers can be mounted in the space provided.

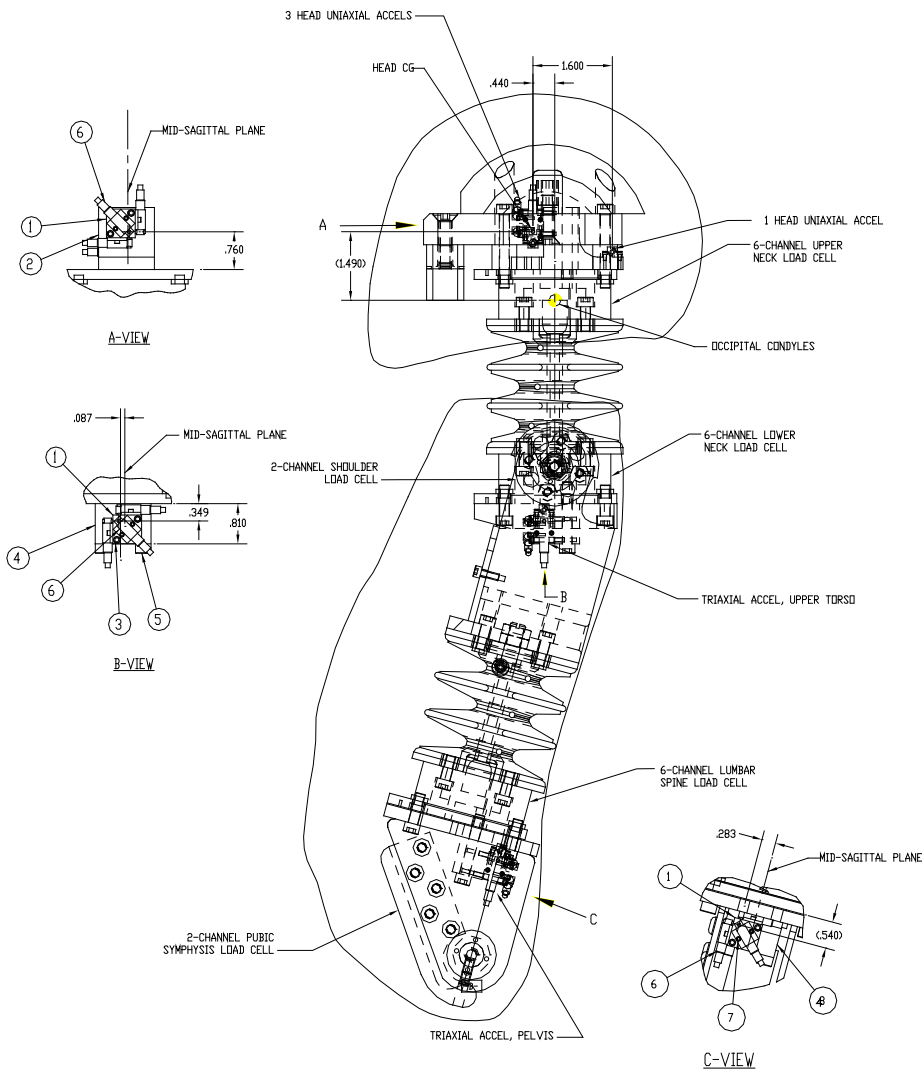

Figure 3. Instrumentation Locations

ITEM	QTY	PART NO.	DESCRIPTION
1	3	H350-1005	TRIAxIAL MOUNT BLOCK
2	1	921022-008	ACCEL MOUNT, HEAD
3	6	9000531	SCREW, SHCS #2-56 X 5/8
4	1	921022-061	TRIAxIAL BLOCK MOUNT, CHEST
5	4	9000288	SCREW, SHCS #10-32 X 1-1/4
6	10	ENDEVCO 7264-2000	ACCELEROMETER (REF)
7	20	9000152	SCREW, SHCS #0-80 X 1/8
8	1	921022-062	TRIAxIAL BLOCK MOUNT, PELVIC

Table 2. Instrumentation Parts List

Section 2. Disassembly Procedures

2.1 Head Assembly

The head assembly, Figure 4, consists of the head, (921022-001), head accelerometer mounting block, (921022-008) and the upper neck transducer structural replacement (910420-003) or the upper neck transducer (SA572-S23).

Remove the four 10-32 x 1-1/2 SHCS (Item 1, Figure 4) which attach the head to the upper neck transducer structural replacement or the upper neck transducer (Item 5, Figure 4). After removing the screws, lift the head vertically until the base of the skull clears the accelerometer mounting block.

Remove the head accelerometer mounting block (Item 3, Figure 4) by removing the two 10-32 x 1-1/2 SHCS (Item 2, Figure 4).

Remove the upper transducer structural replacement (Item 5, Figure 4) or the transducer from the neck by removing the four 10-32 x 5/8 SHCS (Item 4, Figure 4).

2.2 Limbs and Torso Flesh

Due to size differences, the twelve- and eighteen-month dummies differ in part numbers for the upper and lower arms, the thighs and lower legs, and the torso flesh. The part numbers for each are presented in the table accompanying Figure 5.

Remove each arm assembly by removing the 5/16 x 1/2 SHSS (Item 1, Figure 5) from the shoulder end of each upper arm (Item 2, Figure 5). Separate the upper arm and lower arm (Item 4, Figure 5) by removing the 1/4 x 3/8 SHSS (Item 3, Figure 5) at the elbow joint.

Remove each leg assembly by removing the screw 910420-042 (SHSS 5/16 x 5/8 modified Item 5, Figure 5) from the upper thigh (Item 6, Figure 5). Separate the thigh and lower leg (Item 8, Figure 5) by removing the 1/4 x 5/8 SHSS (Item 7, Figure 5) from each knee.

Access holes are provided in the urethane torso flesh at the bottom of the torso for access to the two SSCP 10-32 x 1/4 nylon tip (Item 2, Figures 6) used to lock in the isolation dampers (Item 1, Figures 6), located at the leg/pelvis junction. Loosen the SSCP set screws; then remove the isolation damper from each hip joint.

Unfasten the zipper on the rear of the torso. Remove the torso flesh assembly (Item 6, Figures 6) from the torso structure. Use caution to avoid damaging the skin.

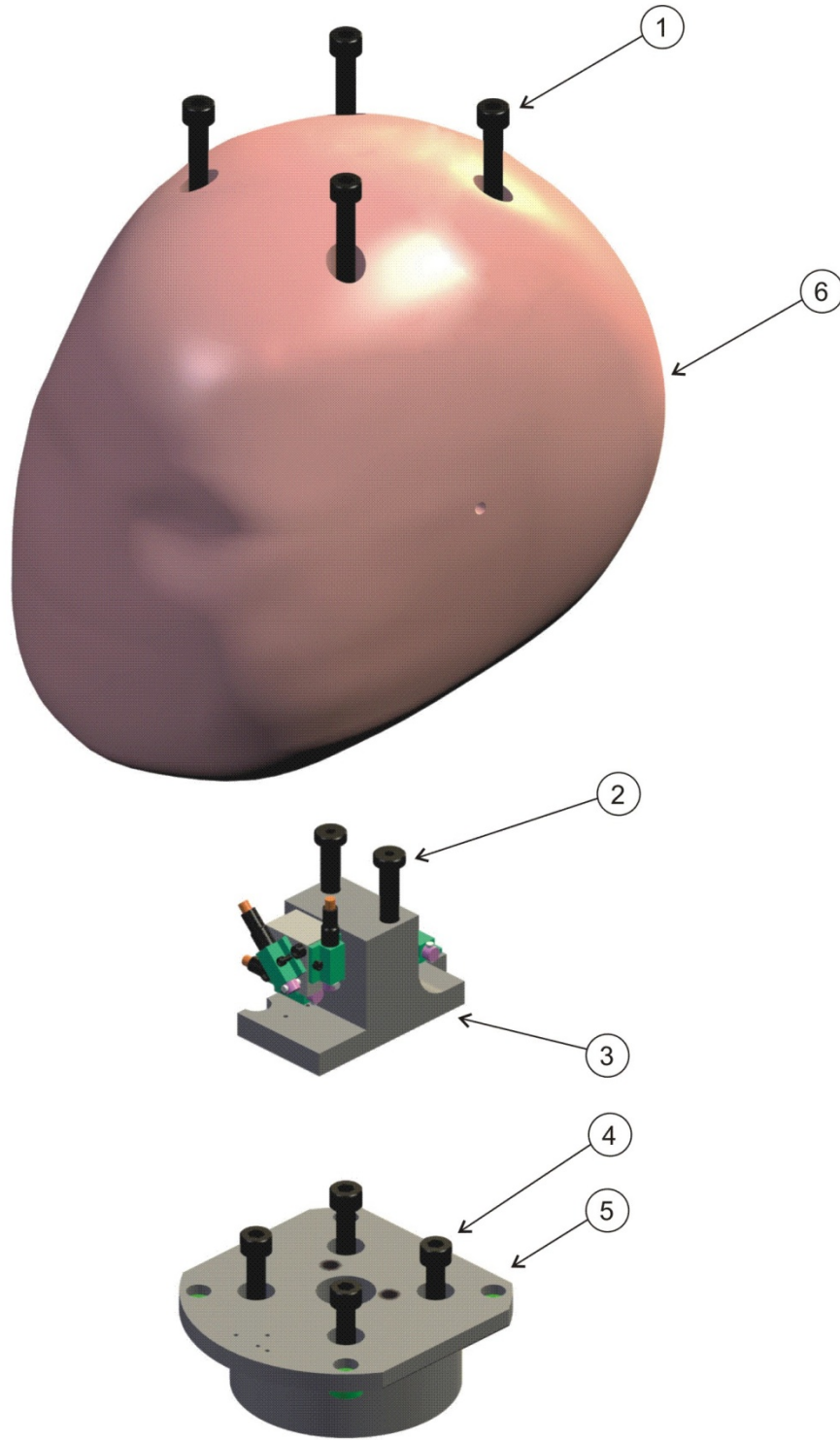

Figure 4. Exploded View, Head Assembly

ITEM	QTY	PART NO.	DESCRIPTION
1	4	9001236	SCREW SHCS, #10-32 X 1 1/2
2	2	9002923	SCREW LHCS, #10-32 X 1 1/2
3	1	921022-008	HEAD ACCELEROMETER MOUNT
4	4	9000137	SCREW SHCS, #10-32 X 5/8
5	1	921022-003	NECK TRANSDUCER STRUCTURAL REPLACEMENT
6	1	921022-001	HEAD MOLDED

Table 3. Head Assembly, Parts List

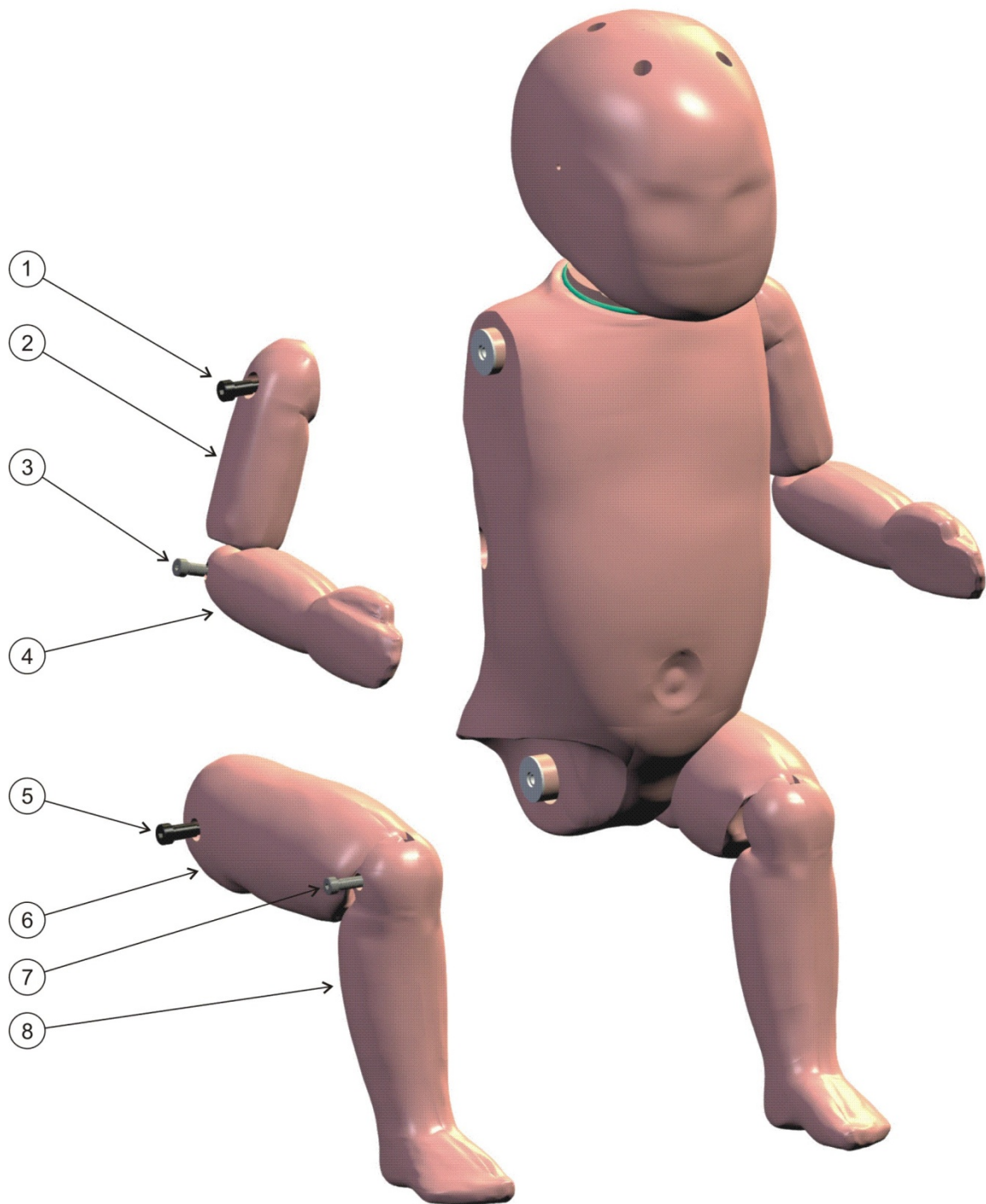

Figure 5. Exploded View, Limb Assembly

ITEM	12 MO. PART NO.	18 MO. PART NO.	DESCRIPTION
1	910420-043	910420-043	SCREW SHSS, 5/16 X 1/2
2	921022-014L/R	930910-005L/R	UPPER ARM
3	9000227	9000227	SCREW SHSS, 1/4 X 3/8
4	921022-017L/R	930910-004L/R	LOWER ARM
5	910420-042	910420-042	SCREW SHSS, 5/16 X 5/8 MODIFIED
6	921022-014L/R	930910-003L/R	UPPER LEG
7	9000619	9000619	SCREW SHSS, 1/4 X 5/8
8	921022-029L/R	930910-002L/R	LOWER LEG/FOOT

Table 4. Limb Assembly, Parts List

2.3 Neck and Torso

The procedure for disassembling the remaining components differs slightly for each dummy due to additional and/or slight differences in the components, which make the eighteen-month-old slightly larger. For clarification purposes, the procedure for each dummy is presented separately in the following paragraphs. The part numbers for the twelve-month-old torso are presented in the table accompanying Figure 6 and 7. The part numbers for the eighteen-month-old torso are presented in the table accompanying Figures 8 and 9. Neck and lumbar spine part numbers are the same for all CRABI dummies and are presented in the table accompanying Figure 10.

2.3.1 Twelve-Month-Old

Remove the abdominal insert (Item 3, Figure 6). The insert is not fastened to the torso.

Remove the two 6-32 x 3/8 SHCS (Item 4, Figure 6) to remove the chest foam and support plate assembly (Item 5, Figure 6).

Remove the two 10-32 x 1-1/4 SHCS (Item 6, Figure 7) to remove the chest accelerometer mount (Item 15, Figure 7) from the transducer structural replacement or transducer (Item 1, Figure 7) by accessing the screws through the back of the spine box (Item 4, Figure 7).

Remove the four 10-32 x 5/8 SHCS (Item 5, Figure 7) to remove the lower neck transducer structural replacement assembly (Item 1, Figure 7) from the thorax by sliding it fore or aft.

Remove the four 10-32 x 1/2 SHCS (Item 2, Figure 7) to separate the lower neck transducer structural replacement or transducer from the neck (Item 11, Figure 7).

Remove the 5/16 - 18 jam nuts (Item 13, Figure 7) and unscrew the two shoulder isolation dampers with the attached shoulder bolt extension (Item 12, Figure 7). Do not remove extension, which should be permanently attached.

Remove the four 10-24 x 5/8 FHCS (Item 14, Figure 7) attaching each shoulder transducer structural replacement (Item 3, Figure 7) or transducer.

Remove the four 10-32 x 1/2 SHCS (Item 2, Figure 7) to separate the spine box (Item 4, Figure 7) from the top of the lumbar spine (Item 11, Figure 7).

Remove the four 10-32 x 5/8 SHCS (Item 5, Figure 7) to separate the lumbar spine/transducer structural replacement assembly (Item 8, Figure 7) from the pelvic structure assembly (Item 9, Figure 7).

Remove the two 10-32 x 1-1/4 SHCS (Item 6, Figure 7) to remove the pelvis accelerometer mount (Item 12, Figure 7).

Note: Accelerometer and/or mounting cube (SAE572-S80) if present must be removed first.

Remove the four 10-32 x 1/2 SHCS (Item 2, Figure 7) to remove the lumbar spine transducer and/or the transducer structural replacement from the lumbar spine (Item 11, Figure 7).

Remove the five 10-24 x 3/8 BHCS (Item 7, Figure 7) to remove the pubic transducer structural replacement (Item 8, Figure 7) or transducer from the pelvis structure.

To disassemble the neck and lumbar spine remove the two 5/16-24 hex nuts (Item 6, Figure 9) and two washers (Items 4 & 5, Figure 9) and remove the cable assembly (Item 1, Figure 9) from the neck. The mounting plate insert (Item 2, Figure 9) does not require removal unless damaged. (Attempts to remove may cause damage.)

This concludes the disassembly instructions for the twelve-month-old dummy. Each component should be inspected to ensure there is not any visible damage that could affect the performance of the dummy. Refer to the Section 2.4 on Damage Inspection.

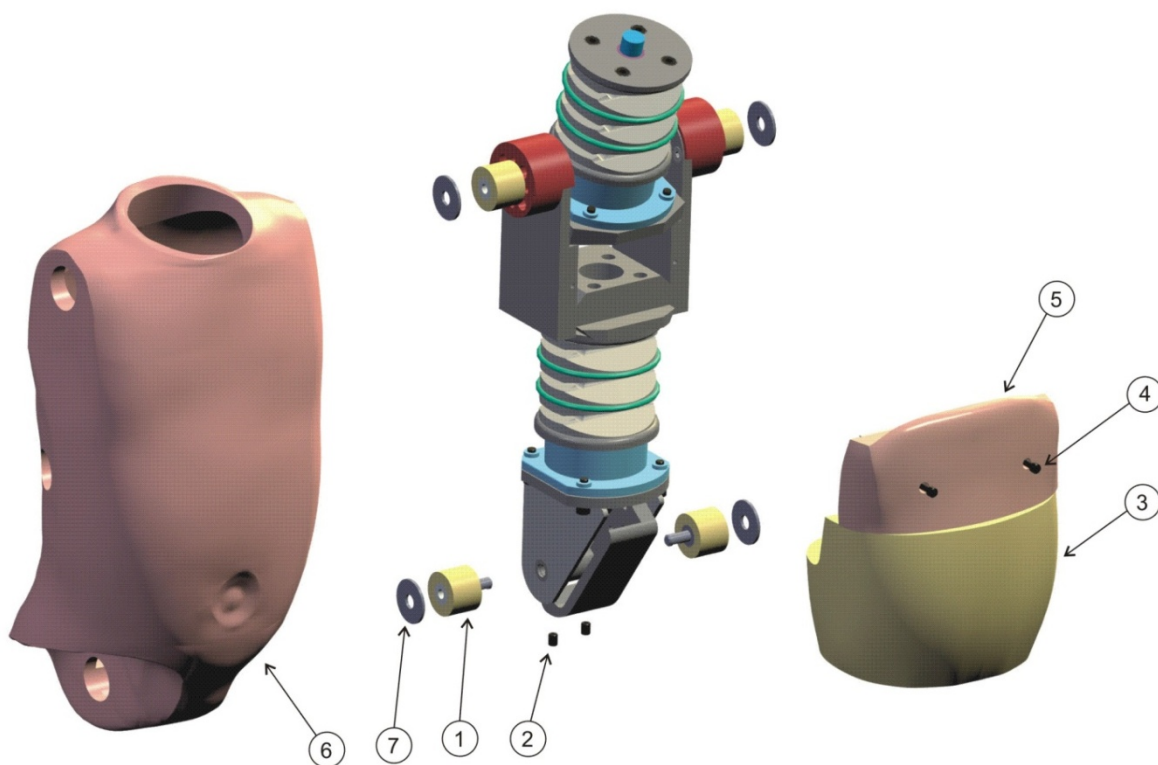

Figure 6. Removal of torso flesh, abdomen and chest foam (12 and 18 mo.)

ITEM	QTY	PART NO.	DESCRIPTION
1	4	910420-056	HIP ISOLATION DAMPER
2	2	9001014	SCREW SSCP, #10-32 X 1/4
3	1	921022-042	ABDOMINAL INSERT
4	2	9000379	SCREW SHCS, #6-32 X 3/8
5	1	921022-040	CHEST FOAM/PLATE
6	1	921022-021	TORSO FLESH
7	4	ATD-3051-4	FRICTION WASHER

Table 5. 12 and 18 mo. Parts List

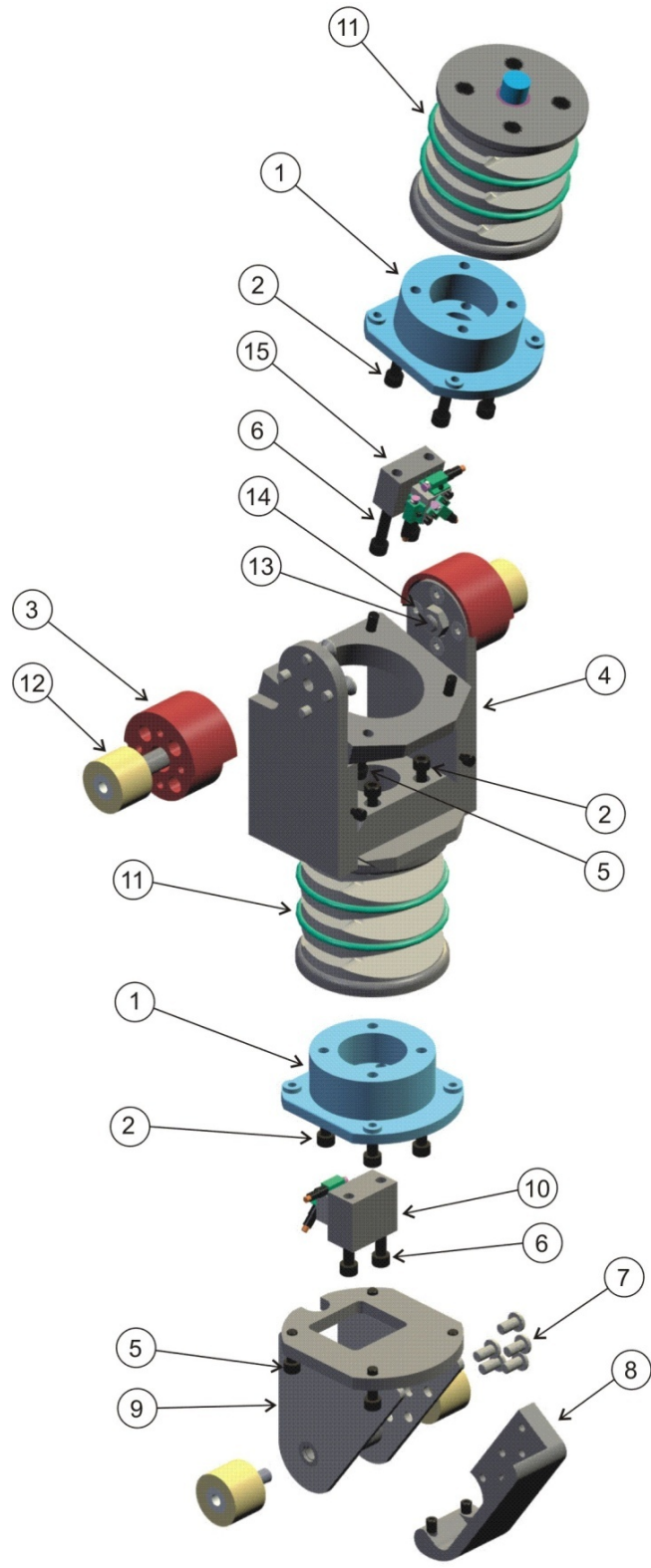

Figure 7. Exploded View, Torso and Neck (12 mo.)

ITEM	QTY	PART NO.	DESCRIPTION
1	2	910420-003	NECK TRANSDUCER STRUCTURAL REPLACEMENT
2	12	9000147	SCREW SHCS, #10-32 X 1/2
3	2	921022-022	SHOULDER TRANSDUCER STRUCTURAL REPLACEMENT
4	1	921022-031	SPINE BOX
5	8	9000137	SCREW SHCS, #10-32 X 5/8
6	4	9000288	SCREW SHCS, #10-32 X 1 1/4
7	5	9000290	SCREW BHCS, #10-24 X 3/8
8	1	921022-050	PUBIC TRANSDUCER STRUCTURAL REPLACEMENT
9	1	921022-035	PELVIC STRUCTURE WELDMENT
10	1	921022-062	PELVIC ACCELEROMETER MOUNT
11	2	921022-041	NECK/LUMBAR ASSEMBLY
12	4	9403-374	SHOULDER ASSEMBLY
13	2	9000656	JAM NUT 5/16-18
14	8	9000566	SCREW FHCS, #10-24 X 5/8
15	1	921022-061	CHEST ACCELEROMETER MOUNT

Table 6. 12 mo. Torso and Neck, Parts List

2.3.2 Eighteen-Month-Old

Remove the abdominal insert (Item 3, Figure 6). The insert is not fastened to the torso.

Remove the two 6-32 x 3/8 SHCS (Item 4, Figure 6) to remove the chest foam and support plate assembly (Item 5, Figure 6).

Remove the two 10-32 x 1 1/4 SHCS (Item 5, Figure 8) to remove the chest accelerometer mount (Item 17, Figure 8) from the transducer structural replacement (Item 1, Figure 7) or transducer by accessing the screws through the back of the spine box (Item 4, Figure 8).

Remove the four 10-32 x 1-1/8 SHCS (Item 6, Figure 8) to remove the lower neck transducer structural replacement assembly (Item 1, Figure 8) and neck adapter (Item 18, Figure 8) from the thorax by sliding it fore or aft.

Remove the four 10-32 x 1/2 SHCS (Item 2, Figure 8) to separate the lower neck transducer structural replacement or transducer from the neck (Item 1, Figure 8).

Remove the 5/16 - 18 jam nuts (Item 15, Figure 8) and unscrew the two shoulder isolation dampers with attached shoulder bolt extension (Item 4, Figure 8). Do not remove extension, which should be permanently attached.

Remove the four 10-24 x 5/8 FHCS (Item 16, Figure 8) attaching each shoulder transducer structural replacement (Item 3, Figure 8) or transducer.

Remove the four 10-32 x 1 1/4 SHCS (Item 5, Figure 8) to separate the spine box from the torso adapter (Item 13, Figure 8) and lumbar spine (Item 12, Figure 8).

Remove the four 10-32 x 5/8 SHCS (Item 10, Figure 8) to separate the lumbar spine/transducer structural replacement assembly (Item 1, Figure 8) from the pelvic structure assembly (Item 9, Figure 8).

Remove the two 10-32 x 1 1/4 SHCS (Item 5, Figure 8) to remove the pelvis accelerometer mount (Item 11, Figure 8).

Note: Accelerometer and/or mounting cube (SAE572-S80) if present must be removed first.

Remove the four 10-32 x 1/2 SHCS (Item 2, Figure 8) to remove the lumbar spine transducer or the transducer structural replacement from the lumbar spine (Item 12, Figure 8).

Remove the five 10-24 x 3/8 BHCS (Item 7, Figure 8) to remove the pubic transducer structural replacement (Item 8, Figure 8) or transducer from the pelvis structure.

To disassemble the neck and the lumbar spine, remove the two 5/16-24 hex nuts (Item 6, Figure 9) and two washers (Items 4 and 5, Figure 9) and remove the cable assembly (Item 1, Figure 9) from the neck. The mounting plate insert (Item 2, Figure 9) does not require removal unless damaged. (Attempts to remove it may cause damage).

This concludes the disassembly instructions for the eighteen-month-old dummy. Each component should be inspected to ensure there is no visible damage that could affect the performance of the dummy. Refer to the Section 2.4 on Damage Inspection.

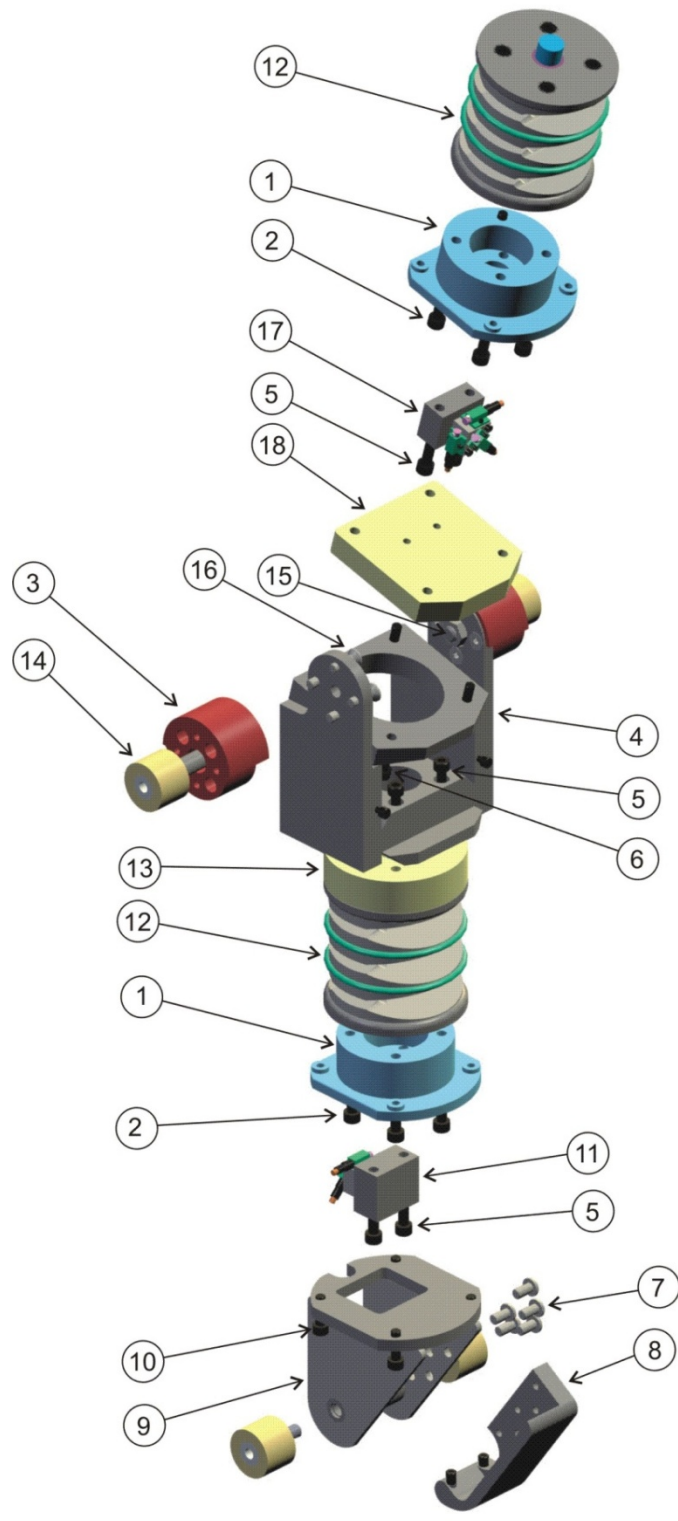

Figure 8. Exploded View, Torso and Neck (18 mo.)

ITEM	QTY	PART NO.	DESCRIPTION
1	2	910420-003	NECK TRANSDUCER STRUCTURAL REPLACEMENT
2	8	9000147	SCREW SHCS, #10-32 X 1/2
3	2	921022-022	SHOULDER TRANSDUCER STRUCTURAL REPLACEMENT
4	1	921022-031	SPINE BOX
5	8	9000288	SCREW SHCS, #10-32 X 1 1/4
6	4	9002075	SCREW SHCS, #10-32 X 1 1/8
7	5	9000290	SCREW BHCS, #10-24 X 3/8
8	1	921022-050	PUBIC TRANSDUCER STRUCTURAL REPLACEMENT
9	1	921022-035	PELVIC STRUCTURE WELDMENT
10	4	9000137	SCREW SHCS, #10-32 X 5/8
11	1	910420-005	PELVIC ACCELEROMETER MOUNT
12	2	921022-041	NECK/LUMBAR ASSEMBLY
13	1	930910-007	TORSO ADAPTOR
14	4	910420-019	SHOULDER ISOLATION DAMPER
15	2	9000656	JAM NUT 5/16-18
16	8	9000566	SCREW FHCS, #10-24 X 5/8
17	1	910420-004	CHEST ACCELEROMETER MOUNT
18	1	930910-006	NECK ADAPTOR

Table 7. 18 mo. Torso and Neck, Parts List

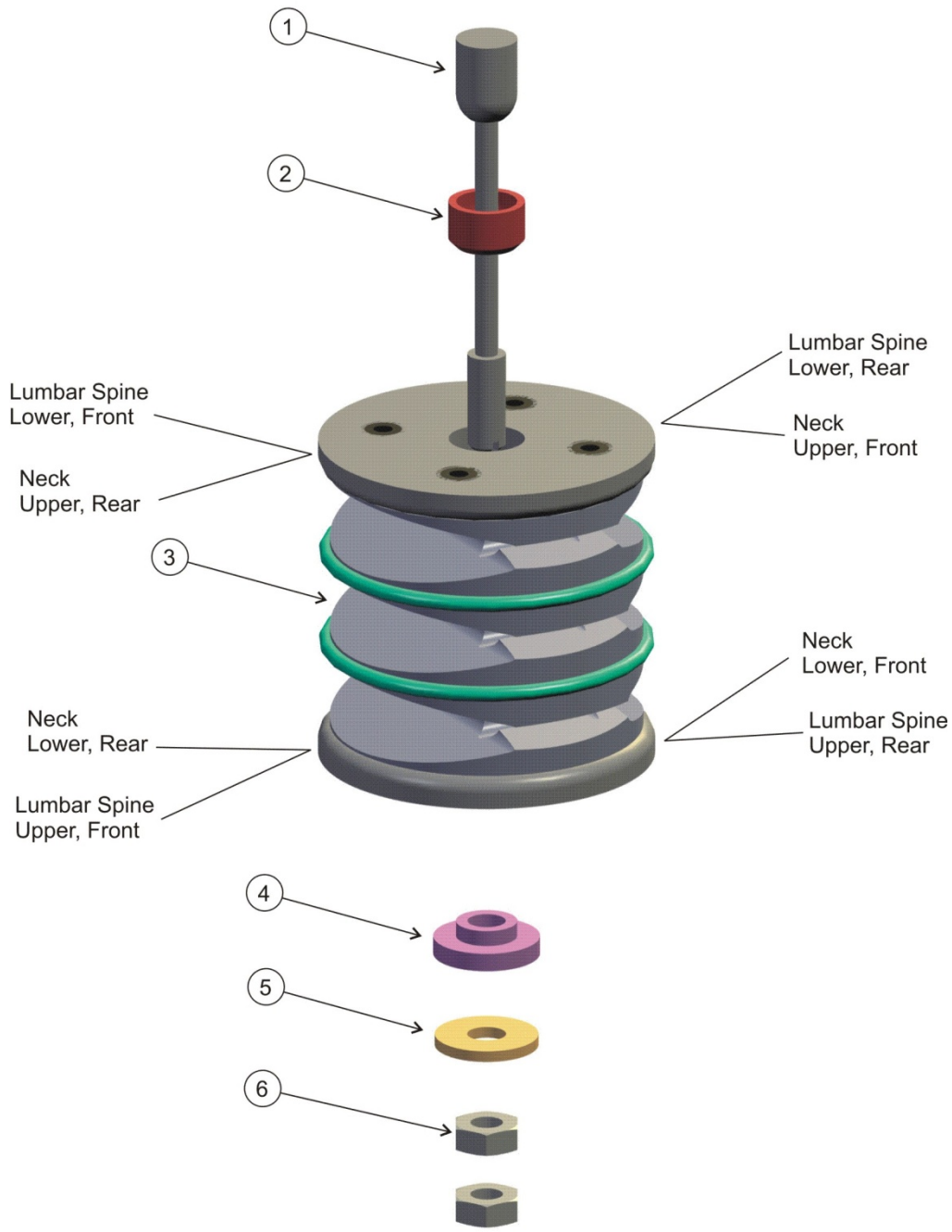

Figure 9. Exploded View, Neck and Lumbar

ITEM	QTY	PART NO.	DESCRIPTION
1	1	ATD-6206	CABLE-NECK/LUMBAR
2	1	910420-048	MOUNTING PLATE, INSERT
3	1	921022-051	NECK/LUMBAR MOLDED ASSEMBLY
4	1	910420-049	COMPRESSION WASHER
5	1	9001358	NYLON WASHER
6	2	9001336	JAM NUT

Table 8. Neck and Lumbar Parts List

2.4 Damage Inspection

2.4.1 General Inspection

An important function in caring for the CRABI test dummy is the diligent and frequent inspection of the complete dummy. It is in this practice that the user can find potential failures and damage and thus avoid needless loss of test time.

The inspection should cover the entire dummy. View each possible section of the dummy. A careful inspection of the dummy can reveal many items of importance. Seemingly small factors could easily add up to invalid test data and loss of test time.

2.4.2 Head

- Check the head skin for cracks or tears. Repair the head skin as indicated in Appendix B. Do not repair damage in the forehead region as this will affect test results. Instead, replace the head or send the head to manufacturer for remolding.
- Check the skull interior for cracks. Replace the head if damaged in any way.

2.4.3 Neck

- Check the neck for unusual or permanent deformations, and tears or breaks in the rubber.
- Replace the neck if you notice any of these problems. Check the neck cable by observing the strands. If they are not tightly wound or the cable seems fatter on one end, replace the cable. If the cable cannot be properly torqued, replace the cable.

2.4.4 Upper/Lower Torso

- Check the chest plate/foam for tears and deterioration. Replace if necessary.
- Check the abdomen foam insert for tears or deterioration. Replace if necessary.

2.4.5 Shoulder

- Check the rubber joint damper to make sure that it is not torn or damaged. If it is torn, replace it.
- Check torso flesh for tears. Repair as instructed in Appendix B or replace.

2.4.6 Hip

- Check the rubber joint damper to make sure that it is not torn or damaged. If it is torn, replace it.

2.4.7 Limbs (all)

- Check all limbs for rips or tears. If damaged, small tears or rips may be repaired as instructed in Appendix B.
- If any limb flesh has been seriously damaged it can be returned to the manufacturer and re-molded.

Section 3. Assembly Procedures

3.1 General Information

The assembly of the dummy is basically the reverse process of the disassembly instructions. Some special instructions are provided in the paragraphs below. Care should be taken to ensure the correct assembly due to the interchangeability of some of the components. The neck and spine are identical assemblies with differing orientations that can easily be installed incorrectly. Please refer to Figure 9 and the detailed instructions below.

Only two assembly steps differ between the twelvemonth-old and eighteen-month-old: the eighteen-month old requires two torso-lengthening adapters. A neck adaptor above the thoracic spine and a lumbar adaptor below the thoracic spine. This difference is highlighted by bold letters in the instructions below. References to some of the figures and part number tables will also differ between the two dummies.

The assembly description below includes the installation of the transducers currently available for the CRABI twelve and eighteen month old dummies.

3.2 Instrumentation Cable Routing

A significant number of instrumentation cables exit the dummy when it is fully instrumented. The routing of the cables is extremely important to minimize the interference and/or influence they have on the kinematics. The cables should exit through the left and right sides of the chest flesh jacket with approximately half of the cables on either side, Figure 10. Care must also be taken when routing the cables inside the chest flesh jacket to prevent cuts and abrasions to the cables.

Dummy users employing large cable connectors may not be able to fit as many as desired through the two side holes unless a proposed modification to the torso flesh in this area is adopted. For those users an alternative approach can be used to avoid having all cables exit the center hole: feed all accelerometers individually from the outside into the torso flesh through the side holes before mounting the accelerometers onto their respective mounting cubes. This method is not directly addressed below and must be planned carefully to allow for the final installation of the torso flesh.

3.3 Neck and Torso

Follow the twelve-month neck and torso assembly in Figures 6, 7 and 9. Follow the eighteen-month assembly in Figures 6, 8 and 9. The neck and lumbar spine assemblies have the same components and therefore are interchangeable. The paragraph below contains the procedure for installing and adjusting the cable assembly in the neck and/or lumbar spine (refer to Figure 9).

Install the mounting plate insert into the neck or lumbar spine. Insert the cable. Install the rubber and nylon washers with the rubber washer installed first, making certain that the washers are fully seated in the recess. Install the *5/16-24 hex nut* and torque to $.23 \pm 0.02$ N·m (2.0 ± 0.2 in·lb.) using a screwdriver

in the slot at the end of the cable. Flex the assembly back and forth a few times to help seat the cable in the socket. Recheck the torque to ensure it is still correct, install the second 5/16-24 hex nut, and tighten.

Install the lumbar spine load cell (or structural replacement) to the bottom of the assembled lumbar spine with four 10-32 x 1/2 SHCS, (refer to Figure 7 or 8). The correct spine orientation is with the slits to the rear; the deeper cutout and the cable head are to the bottom. The correct load cell orientation is with the rounded plate edge forward.

Install the pelvis accelerometer mount (Item 10, Figure 7 or Item 11, Figure 8) , oriented as shown in Figure 3, on the lumbar spine load cell (or structural replacement) using two 10-32 x 1 1/2 SHCS for the 18 month old, and two 10-32 x 1 1/4 SHCS for the 12 month old.

Install the pubic load cell (or transducer structural replacement) into the pelvis structure by first feeding the transducer cable through the pelvis structure front to rear; then install the five 10-24 x 3/8 BHCS.

Install three accelerometers on the accelerometer mounting cube (SA572-S80). Figure 3 illustrates the correct orientation for SA572-S4 accelerometers in the pelvis. Consult the dummy manufacturer's directions for use of other accelerometer options.

Attach the lumbar spine/transducer (or replacement) assembly to the pelvic structure using four 10-32 x 5/8 SHCS.

Note: one end of a pelvis-to-thorax ground cable may be installed under the head of one of the rear SHCS.

Attach the mounting cube (SA572-S80) with accelerometers to the pelvis accelerometer mount using two 2-56 x 5/8 SHCS. The accelerometer cables along with the pubic load cell cables will route upwards through the slot at the rear of the pelvic structure.

Note: a small adhesive-backed cable tie-down may be installed on the inside side wall of the pelvis structure for cable strain relief.

3.3.1 Twelve Month Old

Attach the thoracic spine box to the top of the lumbar spine using four 10-32 x 1/2 SHCS.

Note: one end of a pelvis-to-thorax ground cable may be installed under the head of one of the rear SHCS. Allow enough ground cable slack for full lumbar spine movement.

3.3.2 Eighteen Month Old

Attach the thoracic spine box and torso adapter to the top of the lumbar spine using four 10-32 x 1 1/4 SHCS.

Note: one end of a pelvis-to-thorax ground cable may be installed under the head of one of the rear SHCS. Allow enough ground cable slack for full lumbar spine movement.

3.3.3 Twelve and Eighteen Month Old

Attach the shoulder transducers (or structural replacements) to the thoracic spine box using four 10-24 x 5/8 FHCS on each side.

Screw the two shoulder isolation dampers with shoulder bolt extension into the spine box. Install 5/16-18 jam nuts to hold each damper from turning.

Install the lower neck transducer (or structural replacement) to the pre-assembled neck assembly using four 10-32 x 1/2 SHCS. Neck assembly instructions are given in the second paragraph under Neck and Torso above. (Refer to Figure 9). The correct orientation of the neck is with the slits to the front; the deeper cutout and the cable head are to the top. The correct load cell orientation is with the rounded plate edge forward.

3.3.4 Twelve Month Old

Slide the lower neck load cell (or replacement) with attached neck into the correct orientation at the top of the spine box and install with four 10-32 x 5/8 SHCS.

Note: one end of a thorax-to head ground cable may be installed under the head of one of the rear SHCS.

3.3.5 Eighteen Month Old

Slide the lower neck load cell (or replacement) with attached neck into the correct orientation at the top of the spine box and install with four 10-32 x 1 1/8 SHCS. Make sure the neck adaptor is installed between the neck load cell and the spine box.

Note: one end of a thorax-to-head ground cable may be installed under the head of one of the rear SHCS.

3.3.6 Twelve and Eighteen Month Old

Install three accelerometers on accelerometer mounting cube SA572-S80. Figure 3 illustrates the correct orientation for SA-572-S4 accelerometers in the thorax. Consult the dummy manufacturer instructions for use of other accelerometer options.

Install the mounting cube with accelerometers onto the thoracic accelerometer mount, oriented as in Figure 3, using two 5/16 x 5/8 SHCS.

Slip the thoracic accelerometer mount with accelerometers into the correct position below the neck transducer (Figure 3) with the cables extending to the rear. Install the accelerometer mount using two 10-32 x 1 1/4 SHCS. Easiest access with a wrench is through the back of the spine box.

Install the chest foam and support plate assembly using two 6-32 x 3/8 SHCS. Install the abdominal insert which simply lies in position.

3.4 Torso Flesh and Head

Install the upper neck transducer or structural replacement on the top of the neck using four 10-32 x 1/2 SHCS.

Note: one end of a thorax-to-head ground cable may be installed under the head of one of the rear SHCS. Install two (X- and Y- axis) accelerometers on accelerometer mounting cube SA572-S80. Figures 3 & 4 illustrate the correct orientation for SA752-S4 accelerometers in the head.

Install one or two Z-axis accelerometers directly on the head accelerometer mounting block. The rear Z-axis accelerometer, as illustrated in Figures 3 & 4, is optional for rotational analysis. Install the accelerometer cube with X and Y-axis accelerometers on the vertical surface of the head mounting block above the forward Z-axis accelerometer.

Install the head accelerometer mounting block, as illustrated in Figures 3 & 4, using two 10-32 x 1 1/2 SHCS (*low profile*).

Note: the single extra Z-axis accelerometer is toward the rear of the head.

Note: a small adhesive-backed cable tie-down can be installed on top of the transducer/replacement for cable strain relief.

Install the head onto the upper neck transducer or structural replacement using 10-32 x 1 1/2 SHCS, being cautious that accelerometer cables exit freely out the rear of the head.

Prior to installing the torso flesh, lay the torso flesh front side down on the work bench just below the almost assembled dummy which is also front side down. Begin to route cables through the appropriate torso flesh access holes – inside to outside.

Install the dummy torso assembly into the torso flesh, using caution to avoid damage to the skin.

At this point all remaining cable-routing work should be performed (Figure 10). Additional strain-relief aids may be added to the spine box. Be careful to allow enough cable slack for full neck and spine motion. Additional protection for cables may be added to prevent cuts and abrasions against the thorax structure. Zip the torso flesh.

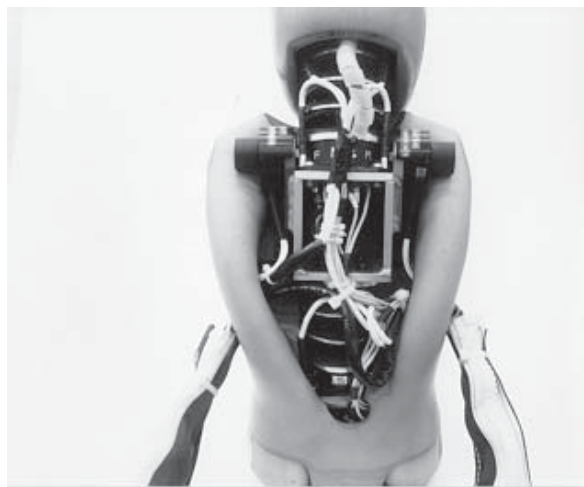

Figure 10. Cable routing rear view

3.5 Limbs

Check that the *10-32 x 1/4 nylon tip SSCP* set screws at the bottom of the torso are backed out. Then slide in the hip isolation dampers on each side of the pelvis. Align the slot on the isolation damper shaft with the set screw. Tighten the SSCP to lock in the isolation dampers.

Attach the left lower leg to the left thigh and the right lower leg to the right thigh using a *1/4 x 5/8 SHSS* in each knee. Attach the respective left and right thighs to the hip isolation dampers using a *5/16 x 5/8 SHSS* in each thigh. (See appendix C for joint adjustment.)

Attach the left lower arm to the left upper arm and the right lower arm to the right upper arm using a *1/4 x 3/8 SHSS* at each elbow joint. Attach the respective left and right arms to the left and right shoulder isolation dampers using a *5/16 x 1/2 SHSS* in each upper arm. (see appendix C for joint adjustment.)

Section 4. Calibration Test Procedures

4.1 Head Drop Test

(A) Two tests measure the head response to frontal and rearward impacts with a hard surface. The CRABI twelve- and eighteen-month-old dummies have identical head test procedures and different response requirements, refer to paragraph (I). (**Note:** The CRABI six-month varies in mass and in head drop response).

(B) The head assembly consists of:

- head assembly, drawing 921022-001.
- accelerometer mounts with accelerometers.
- transducer structural replacement, drawing 910420-003 or transducer, SA- 572-S23.
- four 10-32 x 1 ½ SHCS

The mass of the head assembly including the accelerometers and load cell (or structural replacement) is 2.64 +/- 0.05 kg (5.81 +/- 0.11 lb).

(C) The test fixture consists of a structure to suspend the head assembly and a rigidly supported, flat, horizontal, steel plate. The plate should be 50.8+/- 2 mm (2.0 +/- 0.08 in.) thick, with a length and width of 610 +/- 10 mm (24 +/- 0.4 in.), and have a smooth surface finish of 8 to 80 micro inches/inch rms. A surface finish close to 8 micro inch/inch rms is preferred. The suspension system and accelerometer cable masses should be as light as possible to minimize the external forces acting on the head.

(D) **The Data Acquisition System**, including transducers, must conform to the requirements of the latest version of SAE J211. Filter all data channels using Channel Class 1000. Digital filters should be phaseless.

(E) Test Procedure

1. Visually inspect the head skin for cracks, cuts, abrasions, etc. Replace the head skin if abrasions or cuts to the frontal area are more than superficial.
2. Soak the head assembly in a controlled environment with a temperature of 18.9 to 25.6°C (66 to 78°F) and a relative humidity from 10 to 70 percent for at least four hours prior to a test. The test environment should have the same temperature and humidity requirements as the soak environment.
3. Mount the accelerometers in the head so the sensitive axes intersect at the Center of Gravity point (CG), as illustrated in Figure 4. Ensure that all transducers are properly installed, oriented and calibrated. The accelerometer mounting screws should be torqued to the value recommended by the manufacturer. Attach the accelerometer mounting block to the neck transducer or structural replacement using 10-32 SHCS.

4. Install the transducer structural replacement or the upper neck load cell to the base of the skull with four 10-32 x 1-1/2 SHCS.

5. Prior to the test, clean the surface of the impact plate with isopropyl alcohol or equivalent. Also clean the impact surface of the skin with isopropyl alcohol. Apply a light coating of talcum powder to the skin and wipe with a cloth to remove the excess. This is to eliminate any tackiness on the impact surface due to the cleaning. The impact surface and the skin must be clean and dry for testing.

(F) Test Setup - Frontal Impact

1. Suspend the head assembly in a manner similar to that shown in Figure 11. The assembly is positioned so the angle between the lower surface of the transducer structural replacement or transducer and the impact surface is 45 +/- 1 degree. The impact point is on the midsagittal plane. The 3.30mm holes in the head which indicate CG alignment may be used to level the head.

2. Drop the head assembly from a height of 376 +/- 1mm (14.8 +/- 0.04 in) by a means that ensures a smooth, instant release onto the impact surface.

3. Wait at least two hours between successive tests, at the same impact point, of the head assembly.

4. Time-zero is defined as the point of contact between the head and the impact surface. All data channels should be at the zero level at this time.

(G) Performance Specifications - Frontal Impact

1. The peak resultant acceleration should be not less than 100 G's, and not more than 120 G's.

2. The resultant acceleration vs. time history curve should be unimodal; oscillations occurring after the main pulse should be less than 17 percent of the peak resultant acceleration.

3. The lateral acceleration should not exceed 15 G's.

(H) Test Setup - Rear Impact

1. Suspend the head assembly in a manner similar to that shown in Figure 12. The assembly is positioned so the angle between the lower surface of the transducer structural replacement or transducer and the impact surface is 90 +/- 1 degree. The impact point is on the midsagittal plane. The 3.30mm holes in the head which indicate CG alignment may be used to level the head.

2. Drop the head assembly from a height of 376 +/- 1mm (14.8 +/- 0.04 in) by a means that ensures a smooth, instant release onto the impact surface.

3. Wait at least two hours between successive tests, at the same impact point, on the head assembly.

4. Time-zero is defined as the point of contact between the head and the impact surface. All data channels should be at the zero level at this time.

(I) Performance Specifications - Rear Impact

1. The peak resultant acceleration should be not less than 55 G's, and not more than 71 G's for the 12 month old head. The peak resultant acceleration should be not less than 58 G's, and not more than 70 G's for the 18 month old head.
2. The resultant acceleration vs. time history curve should be unimodal; oscillations occurring after the main pulse should be less than 17 percent of the peak resultant acceleration for the 12 month old and 16 percent for the 18 month old head.
3. The lateral acceleration should not exceed 15 G's for both 12 and 18 month old heads.

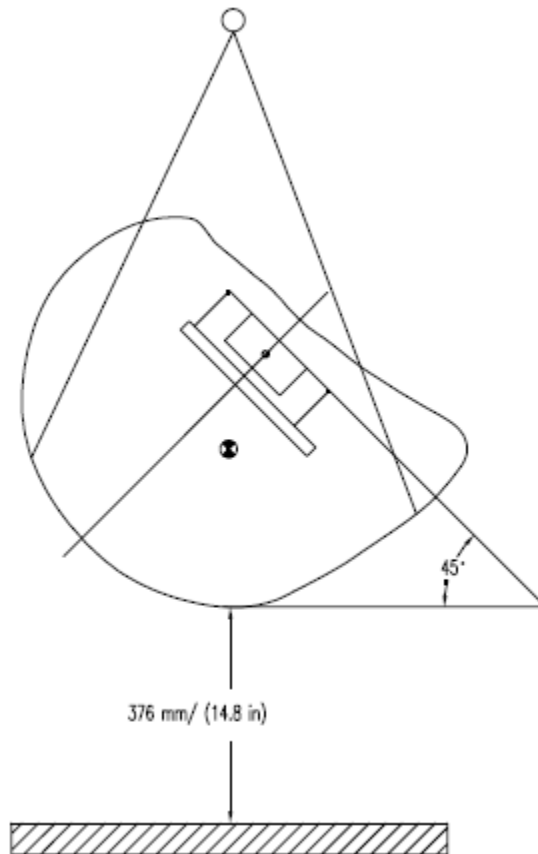

Figure 11. Head Drop Test Setup (Frontal Impact)

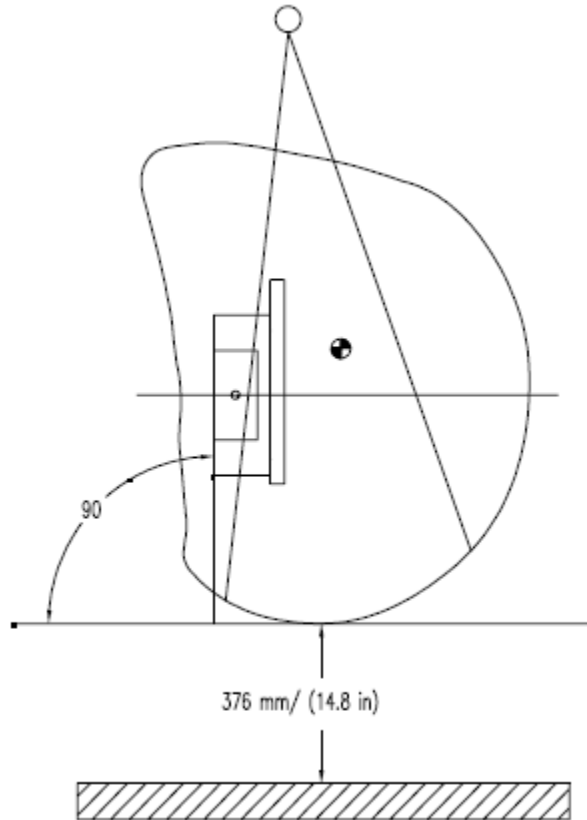

Figure 12. Head Drop Test Setup (Rear Impact)

4.2 Neck Tests

The components required for the neck tests are:

- Part 572, subpart 'E', Neck Pendulum including H3-50 Neck Mounting Plate
- CRABI Neck Adapter Plate TE-3200-160
- Rotation Measurement Unit
- Force/Moment Measurement Unit (load cell) SA572-S23
- Neck Assembly 921022-041
- Head Form TE-3200-140
- Zeroing Bracket TE-3200-155
- Rotary Pot Simulator TE-3200-130

(A) The neck assembly is the same for the six, twelve and eighteen-month-old infant dummies, therefore, the headform and test procedures for flexion and extension testing of the neck are the same for all three CRABI sizes. The lumbar spine in each of the dummies is the same component, so any part used as a spine could be tested as a neck if needed.

(B) The test fixture pendulum arm with specifications appears in Figure 13. The aluminum honeycomb material is commercial grade, 152.4 mm (6.0 in) thick, 28.8 kg/meter³ (1.8 lbs. /ft³) with 19 mm (0.75 in) diameter cells. Mount the accelerometer with its sensitive axis aligned with the arc formed at a radius 1657.4 mm (65.25 in) from the pivot point.

(C) The Data Acquisition System, including transducers, must conform to the requirements of SAE Recommended Practice J211, latest version. Filter the neck My and Fx data channels using phaseless Channel Class 600 (required on both channels for moment calculation), the pendulum acceleration data channel using phaseless Channel Class 180 (required for velocity integration), and the neck rotation data channels using phaseless Channel Class 60.

(D) Calculate the moment about the occipital condyles for both the flexion and extension tests using the formulae:

Note: the moment arm is the distance between the occipital condyle location of the twelve and eighteen-month-old CRABI and the measuring plane of the Y-axis of the neck transducer which is derived from the drawing package.

Metric Units:

Occipital Moment

$$(\text{Nm}) = [\text{My} (\text{Nm})] - [0.005842 (\text{m})] [\text{Fx} (\text{N})]$$

English Units:

Occipital Moment

$$(\text{lb-ft}) = [\text{My} (\text{lb-ft})] - [0.019167 (\text{ft})] [\text{Fx} (\text{lb})]$$

Note: The formulae are based on the sign convention contained in the latest revision of SAE recommended practice J211 and SAE Information Report J1733.

(E) Test Procedure

1. Soak the neck assembly in a controlled environment at a temperature from 20.6 to 22.2 °C (69 to 72 °F) and a relative humidity from 10 to 70 percent for at least four hours prior to a test. The test environment should have the same temperature and humidity requirements as the soak environment.
2. Inspect the neck assembly for cracks, cuts and separation of the rubber from the metal segments. Replace if required.
3. Check all the neck assembly parts that are used in this calibration, which include neck assembly (921022-51), cable (ATD-6206), Jam nut 5/16-24 (9001336), insert (910420-048), and washers (910420-049 and 9001358).

4. Assemble the neck parts, listed above, together according to Figure 9, directions given in the Assembly Procedures section of this manual. Set the cable torque to 0.23 ± 0.02 Nm. (2.0 ± 0.2 in lb). *To properly torque it, the cable must be held with a screwdriver in the slot in the end of the cable. This prevents the cable from winding up as the nut is torqued. Flex the assembly back and forth to help seat the cable; recheck the torque; install the second 5/16-24 hex nut and tighten.*

5. Assemble the neck adapter plate (Item 1, Figures 14 and 15) to the bottom of the neck with four SHCS 10-32 x 1/2. The side face of the bracket adapter plate, which has two 1/4-20 tap holes, should face the back of the neck. It will be used to mount the zeroing bracket later. Refer to Figure 9 for correct neck orientation. It is possible to incorrectly install the neck upside down and/or backwards. The slits are at the front of the neck; the deeper cut out and the cable head are at the top.

6. Install the load cell (Item 2, Figure 14 and 15) on top of the neck with four 10-32 x 5/8 SHCS.

7. Install the head form (Item 3, Figures 14 and 15) to the load cell with four 10-32 x 1 1/2 SHCS. The head form must be installed so that the longer offset is towards the front of the neck (side with the slits).

8. Take the head form/load cell/neck/neck adapter plate assembly and mount the neck adapter plate end with four pieces of 5/16-24 x 1-3/4 SHCS to the H3-50 neck mounting plate (Item 4, Figures 14 and 15) on the end of the pendulum. See Figure 14 for flexion test set-up and Figure 15 for extension test set-up, which differ for this mounting step.

Note: The neck must be mounted on the leading edge of pendulum end to avoid interference.

9. Install the rotary potentiometer assembly on one side and the potentiometer mass simulator assembly to the other side of the head form and pendulum. Tighten the 8-32 x 1/4 SSCP on the columns to secure the pot shaft.

10. Cut the hexcel and mount it on the test fixture frame.

11. Carefully rest the pendulum against the hexcel.

12. Install the zeroing bracket (Item 5, Figures 14 and 15) to the back of the head form and the neck adapter by first installing two 1/4-20 x 1/2 FHCS (Item 6, Figures 14 and 15) towards the neck base and then installing two 1/4-20 x 3/4 SHCS (Item 7, Figures 14 and 15) at the headform end (the two SHCS which fit through slots must be installed last to insure proper alignment).

13. Zero the load cell and rotation measurement data channels. The load cell data channel shall be zeroed to within ± 0.2 N·m. The rotation data channels shall be zeroed within ± 0.2 degrees. *Note: It is important to be aware of zero drift. It is recommended that care should be taken to warm up the data system and transducers according to manufacturers' recommendations before establishing the data channel zero levels. Also, it is recommended to run the tests as soon as possible after the channels are zeroed to further minimize channel zero drift that normally occurs over time.*

14. Remove the zeroing bracket. *Note: If pre-crushing of the honeycomb is to be done, it shall be done prior to bracket removal.*

15. Raise the pendulum to achieve 5.20 ± 0.1 m/s (17.1 ± 0.3 ft/s) for flexion test (approximately 76 degrees), or 2.50 ± 0.1 m/s (8.2 ± 0.3 ft/s) for extension test (approximately 34 degrees).

16. Arm the data acquisition system and release the pendulum to test the neck.

17. Time zero is defined as the time of initial contact between the pendulum striker plate and the honeycomb material. The pendulum accelerometer data channel shall be at the zero level at this time.

18. Wait at least 30 minutes between successive tests on the same neck.

(F) Performance Specifications -Neck Flexion

1. Release the pendulum from an angle and allow it to fall freely to achieve an impact velocity of 5.20 ± 0.10 m/s (17.1 ± 0.3 ft/s), measured at the center of the pendulum accelerometer.

2. Stop the pendulum from the initial velocity with acceleration vs. time pulse which meets the velocity change as specified below. Integrate the pendulum acceleration data channel to obtain the velocity vs. time curve.

3. The maximum rotation of the D-plane of the head should be not less the 75 degrees and not more than 86 degrees with respect to the pendulum longitudinal centerline.

4. The positive moment about the Y-axis of the head, measured with respect to the occipital condyles, should be not less than 36 Nm (26.6 ft-lb) and not more than 45 Nm (33.2 ft-lb) within the minimum and maximum rotation interval of 75 to 86 degrees. The positive moment shall decay for the first time to 5 Nm (3.7 ft-lb) between 60 ms and 80 ms after time zero.

Time	Pendulum Impulse (Flexion)	
	m/s	Ft/s
10	1.6-2.3	5.2-7.5
20	3.4-4.2	11.2-13.8
25	4.3-5.2	14.1-17.1

Table 9. Pendulum Impulse (Flexion)

(G) Performance Specifications- Neck Extension

1. Release the pendulum from an angle and allow it to fall freely to achieve an impact velocity of 2.50 ± 0.10 m/s (8.2 ± 0.3 ft/s), measured at the center of the pendulum accelerometer.

2. Stop the pendulum from the initial velocity with acceleration vs. time pulse which meets the velocity change as specified below. Integrate the pendulum acceleration data channel to obtain the velocity vs. time curve.

3. The maximum rotation of D-plane of the head should be not less than 80 degrees and not more than 92 degrees with respect to the pendulum longitudinal centerline.

4. The negative moment about the Y-axis of the head, measured with respect to the occipital condyles, should be not more than -12 Nm (-8.9 ft-lb) and not less than -23 Nm (-17.0 ft-lb) within the minimum and maximum rotation interval of 80 to 92 degrees. The negative moment shall decay for the first time to -5 Nm (-3.7 ft-lb) between 76 ms and 90 ms after time zero.

Time	Pendulum Impulse (Extension)	
	ms	Ft/s
6	0.8-1.2	2.6-3.9
10	1.5-2.1	4.9-6.9
14	2.2-2.9	7.2-9.5

Table 10. Pendulum Impulse (Extension)

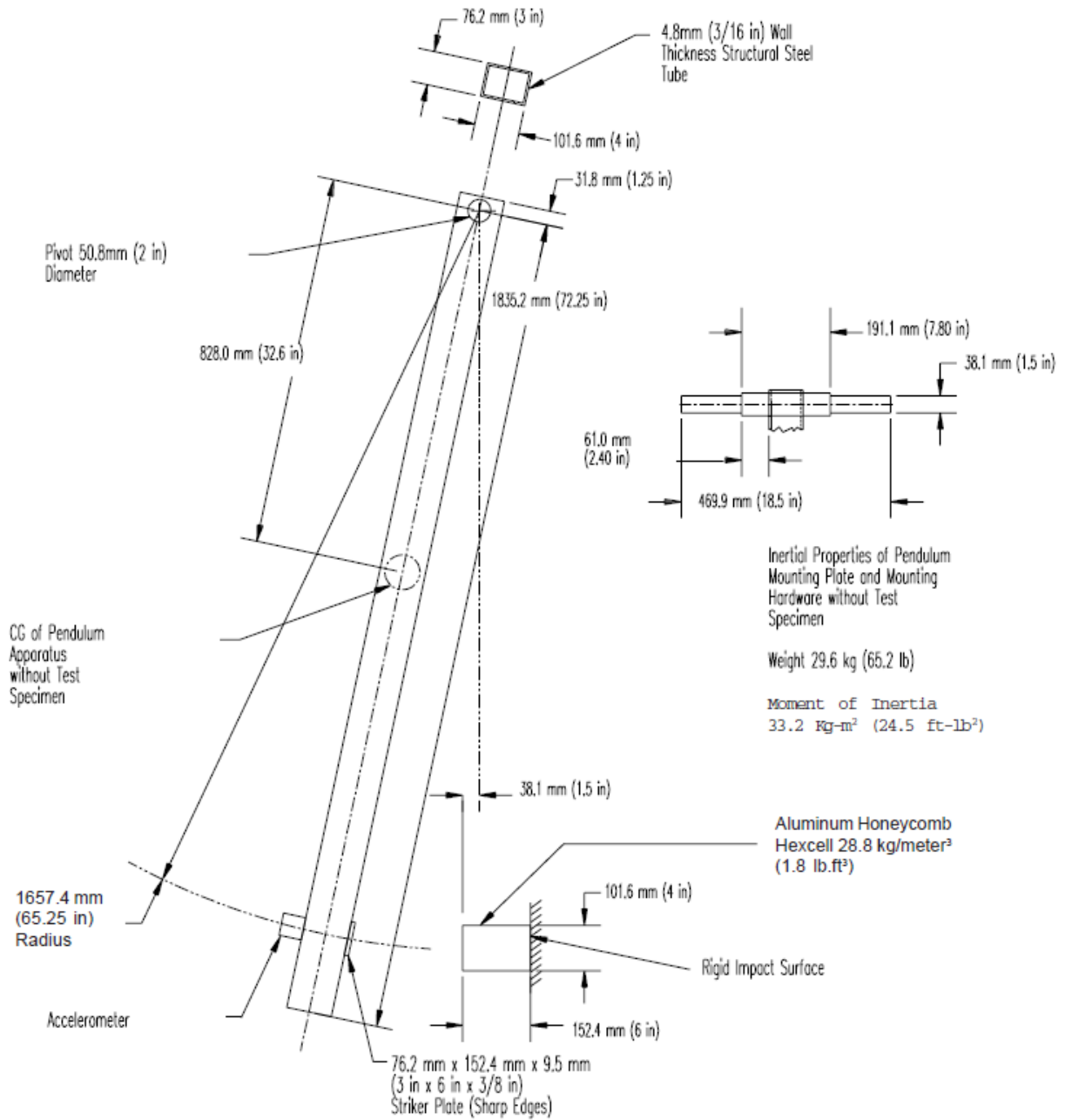

Figure 13. Neck Pendulum Arm Specifications

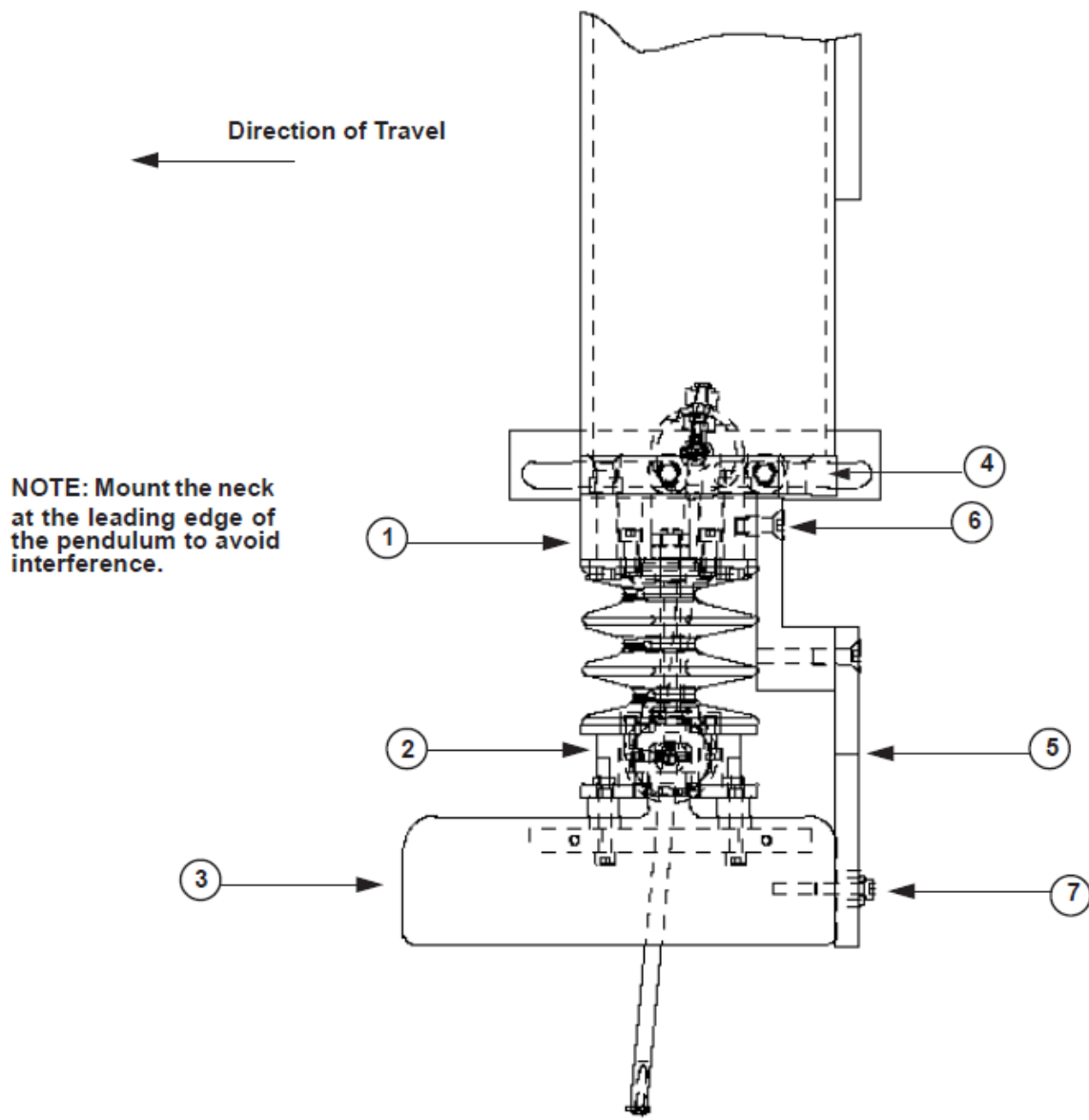

Figure 14. Neck Flexion Test Set-up

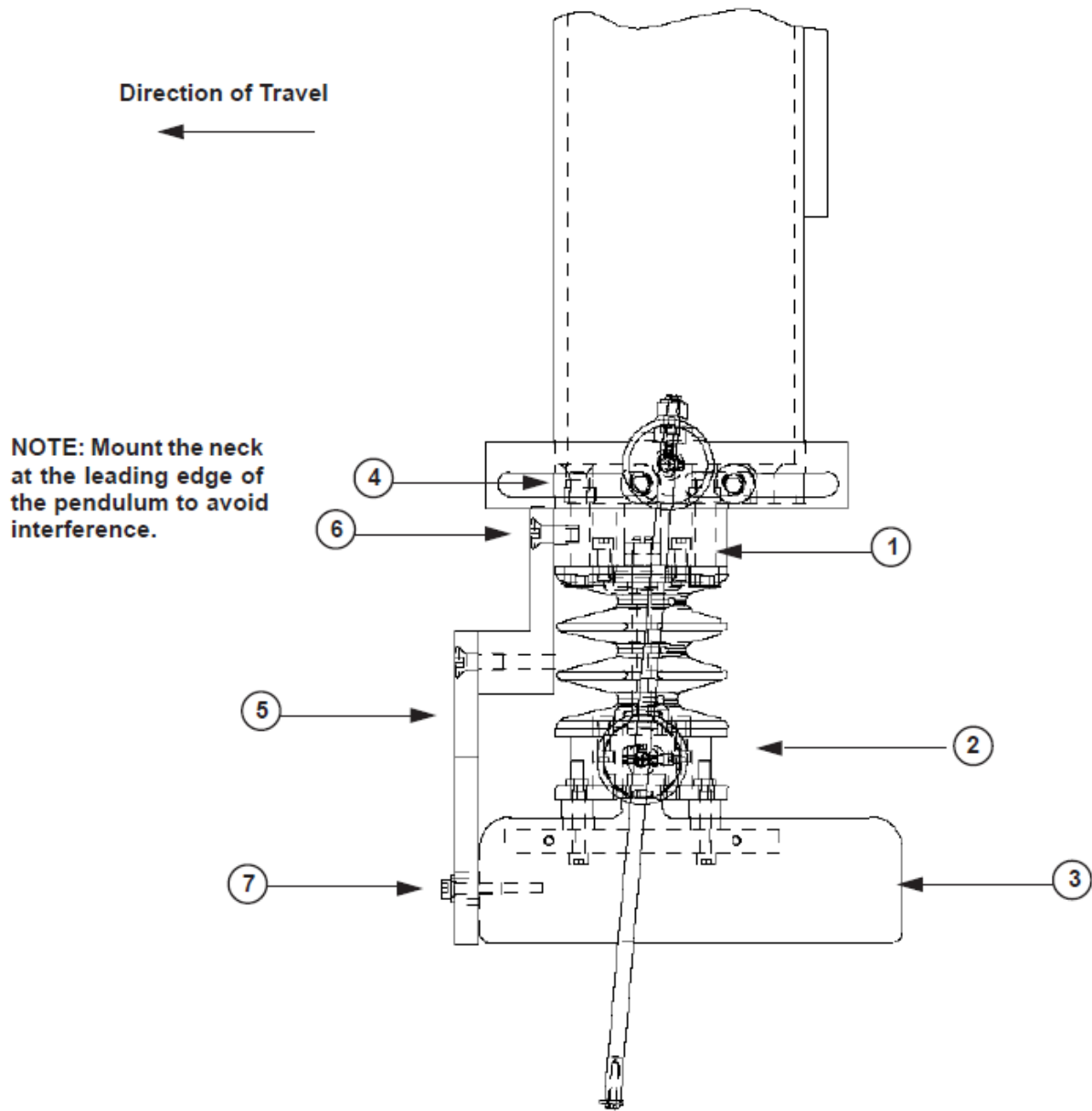

Figure 15. Neck Extension Test Set-up

4.3 Thorax Impact Test

The components required for the thorax tests are:

- Thorax Impact Fixture
- Impact Table w/Stainless Steel Surface
- Impact Probe 2.86 kg (6.3 lb)
- Inclinometer

(A) The complete assembled dummy (Ref. Drawing 921022-000/930910-000) is required, including the clothing [shirt and pant], but without the shoes.

(B) The fixture consists of a smooth, clean, dry, steel seating surface and a rigid test probe. The test probe mass is 2.86 ± 0.02 kg (6.3 ± 0.05 lb) including instrumentation, rigid attachments, and the lower 1/3 of the suspension cable mass. The diameter of the impacting face is 101.6 ± 0.25 mm (4.00 ± 0.01 in) and has a flat, right angle face with an edge radius of 7.6/12.7 mm (0.3/0.5 in). Mount an accelerometer to the probe with its sensitive axis in line with the longitudinal centerline of the test probe.

(C) The data acquisition system, including transducers, must conform to the requirements of SAE recommended Practice J211, latest version. Filter all data channels using phaseless Channel Class 180.

(D) Test Procedure

1. Check the torque of the nuts on the lumbar spine and neck. Reference the appropriate sections of the User's Manual.
2. Reassemble the dummy. Reference the reassembly section of the User's Manual.
3. Soak the test dummy in a controlled environment at a temperature between 20.6 to 22.2° C (69 to 72° F) and a relative humidity from 10 to 70 percent for at least four hours prior to a test. The test environment should have the same temperature and humidity requirements as the soak environment.
4. Check that all transducers are properly installed, oriented and calibrated.
5. Seat the dummy on the test fixture surface. The surface must be long enough to support the pelvis and outstretched legs.
6. Place the arm assemblies 0 to 5 degrees forward of vertical. Place the lower limbs extended outward parallel to the midsagittal plane and 0 to 5° from vertical. Set the limbs to 1-2 g's by tightening the SHSS at the shoulder and hip. Set the upper back plate of the spine box at $90.0^\circ \pm 1.0^\circ$ from the horizontal. The midsagittal plane of the dummy is vertical $\pm 1.0^\circ$ and within 2.0° of being parallel to the centerline of the test probe. (Shim material may be used under the thighs to maintain spine box alignment.) The longitudinal centerline of the test probe is centered on the midsagittal plane of the dummy within ± 2.5 mm (± 0.1 in). Align the test probe so its longitudinal centerline is at 196 ± 2.5 mm (7.7 ± 0.1 in) vertically from the plane of the seating surface and is within ± 0.5 degrees from horizontal.
7. Impact the thorax with the test probe so the probe's longitudinal centerline is within 2° of a horizontal line in the dummy's midsagittal plane at the moment of impact.
8. Guide the probe so no significant off-axis lateral, vertical or rotational motion takes place during the impact.

9. The test probe velocity at the time of impact is 5.0 ± 0.10 m/s (16.5 ± 0.3 ft/s).
10. Time-zero is defined as the time of initial contact between the test probe and the chest skin. All data channels must be at the zero level at this time.
11. Wait at least 30 minutes between successive tests on the same thorax.

(B) Performance Specifications

1. The peak force shall be not less than 1514 N (340.7 LBF) and not more than 1796 N (404.1 LBF). Calculate this force by multiplying the test probe acceleration by its mass.

Hardware for length adjustment should be located near the upper pivot and is not included in the cable weight

Caution: Make sure cables are positioned not to interfere with the dummy during impact.

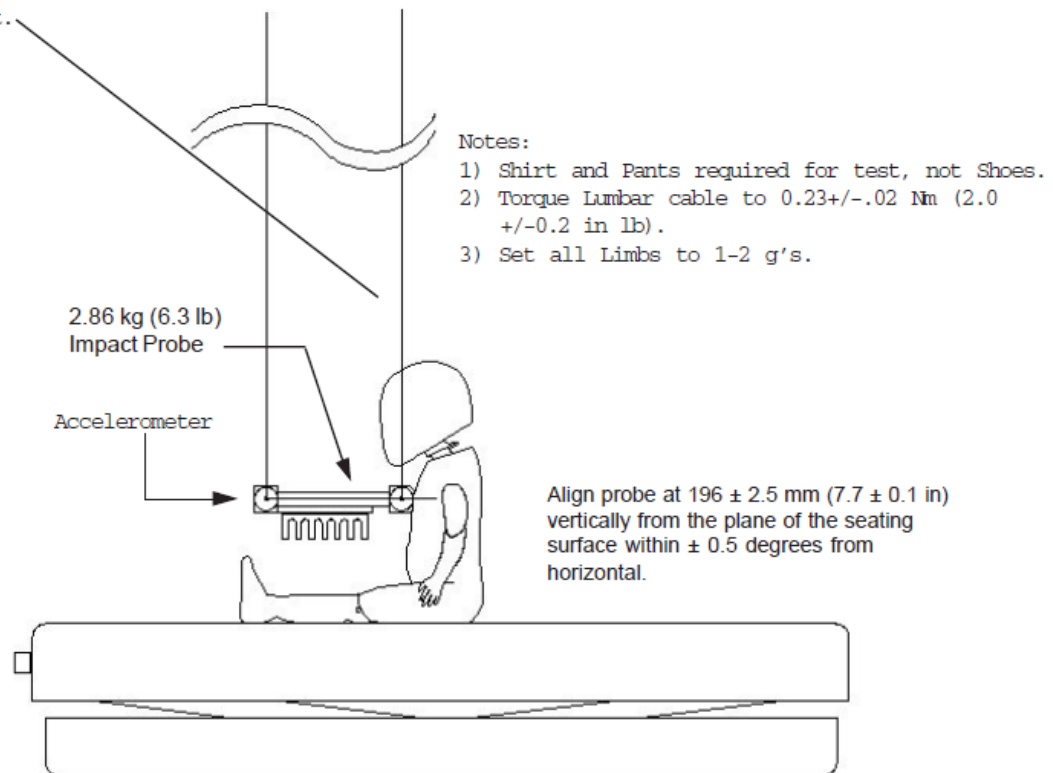

Figure 16. Thorax Impact Set-Up

Section 5. Inspection Test Procedures

5.1 External Dimensions

1. Check the torque of the nuts on the lumbar spine and the neck (Item 6, Figure 9). Reference the appropriate sections of this User's Manual.
2. Reassemble the dummy. Reference the Disassembly Procedure and Assembly Procedure sections of this User's Manual.
3. Place the dummy on a flat, rigid smooth, clean, dry, horizontal surface, as shown in Figure 17. The dummy's midsagittal plane is vertical and centered on the test surface.
4. Secure the dummy to the measuring fixture so that the rear surfaces of the upper torso and buttocks are tangent (or as near tangent as possible) to the rear vertical surface of the fixture. The dummy's midsagittal plane should be vertical.
5. The centerlines of the upper arms are vertical and the lower arms horizontal.
6. The upper legs should be parallel to each other.
7. The lower legs should be perpendicular to the upper legs and the bottoms of the feet horizontal.
8. Record the following dimensions (The symbols and description for each measurement are indicated in Figure 17). They should conform to the dimensions specified in Table 11.
 - A. Total sitting Height - Seat surface to the highest point on top of the head with the head pulled back to touch the vertical surface of the fixture.
 - B. Shoulder Pivot Height – Centerline of shoulder pivot bolt to the seat surface.
 - C. Hip Pivot Height.
 - D. Hip Pivot from Backline.
 - E. Shoulder Pivot from Backline.
 - F. Thigh Clearance – Seat surface to highest point on the upper femur segment.
 - G. Back of Elbow to Finger tip – The back elbow flesh to the fingertip, in line with the elbow and wrist centerlines.
 - I. Shoulder pivot to Elbow Length - The shoulder pivot to the lowest part of the flesh on the elbow, in line with the elbow pivot bolt.
 - J. Elbow Rest Height.
 - K. Buttock to Knee Length - The most forward part of the knee flesh to the fixture's rear vertical surface.
 - L. Popliteal Height - The bottom of the foot to the top of the seat surface.
 - M. Knee Pivot Height.

N. Buttock to Popliteal Length - The most forward portion of the crevice between the upper and lower legs behind the knee to the fixture's rear vertical surface.

O. Chest Depth with Jacket - The distance from the anterior surface of the chest to the fixture's vertical surface, through the midsagittal plane.

P. Foot Length.

Q. Stature - Lay the dummy out on a flat surface with the rear surface of the head, upper torso, buttocks and heels touching the surface and with the bottoms of the feet perpendicular to that surface. Measure the distance from the bottoms of the feet to the top of the head.

R. Buttock to Knee Pivot Length - The knee pivot to the fixture's rear vertical surface.

U. Hip Breadth - The distance across the width of the hip at the widest point.

V. Shoulder Breadth - Between outside edges of the shoulder flesh, in line with the shoulder pivot bolt.

W. Foot Breadth - Widest part of the foot.

Y. Chest Circumference with Jacket - The distance around chest at reference location AA; with the jacket on.

Z. Waist Circumference - The distance around waist at reference location BB, with jacket on.

External Dimension					
Symbol	Description	12 mo. inch	12 mo. mm	18 mo. inch	18 mo. mm
A	Total Sitting Height	18.50±0.30	469.9±7.6	19.70±0.30	500.4±7.6
B	Shoulder Pivot Height	11.19±0.30	284.2±7.6	11.70±0.30	297.2±7.6
C	Hip Pivot Height	1.30±0.20	33.0±5.1	1.40±0.20	35.6±5.1
D	Hip Pivot from Backline	1.78±0.20	45.2±5.1	1.80±0.20	45.7±5.1
E	Shoulder Pivot from Backline	2.18±0.20	55.4±5.1	2.10±0.20	53.3±5.1
F	Thigh Clearance	2.68±0.20	68.1±5.1	3.00±0.20	76.2±5.1
G	Back of Elbow to Finger Tip	7.68±0.30	195.1±7.6	8.30±0.30	210.8±7.6
I	Shoulder to Elbow Length	5.20±0.30	132.1±7.6	5.40±0.30	137.2±7.6
J	Elbow Rest Height	6.21±0.30	157.7±7.6	5.80±0.30	147.3±7.6
K	Buttock to Knee Length	8.28±0.30	210.3±7.6	9.00±0.30	228.6±7.6
L	Popliteal Height	5.76±0.30	146.3±7.6	6.40±0.30	16.26±7.6
M	Knee Pivot Height	6.80±0.30	172.7±7.6	7.50±0.30	190.5±7.6
N	Buttock popliteal length	6.00±0.30	152.4±7.6	7.20±0.30	182.9±7.6
O	Chest Depth with Jacket	4.53±0.30	115.1±7.6	5.00±0.30	127.0±7.6
P	Foot Length	3.84±0.20	97.5±5.1	3.90±0.20	99.1±5.1
Q	Stature	29.15±0.50	740.4±12.7	32.20±0.50	817.9±12.7
R	Buttock to Knee Pivot Length	7.23±0.20	183.6±5.1	8.10±0.20	205.7±5.1
U	Hip Breadth	6.54±0.30	166.1±7.6	6.90±0.30	175.3±7.6
V	Shoulder Breadth	8.20±0.30	208.3±7.6	8.80±0.30	223.5±7.6
W	Foot Breadth	1.74±0.20	44.2±5.1	1.80±0.20	45.7±5.1
Y	Chest Circumference with Jacket	18.31±0.50	465.1±12.7	18.80±0.50	477.5±12.7
Z	Waist Circumference	18.10±0.50	459.9±12.7	17.50±0.50	444.5±12.7
AA	Reference Location for Chest Circumference	10.30±0.20	261.6±5.1	10.30±0.20	261.6±5.1
BB	Reference Location for Waist Circumference	4.4±0.20	111.8±5.1	5.10±0.20	129.6±5.1

Table 11. External Dimensions for 12 and 18 Month Old

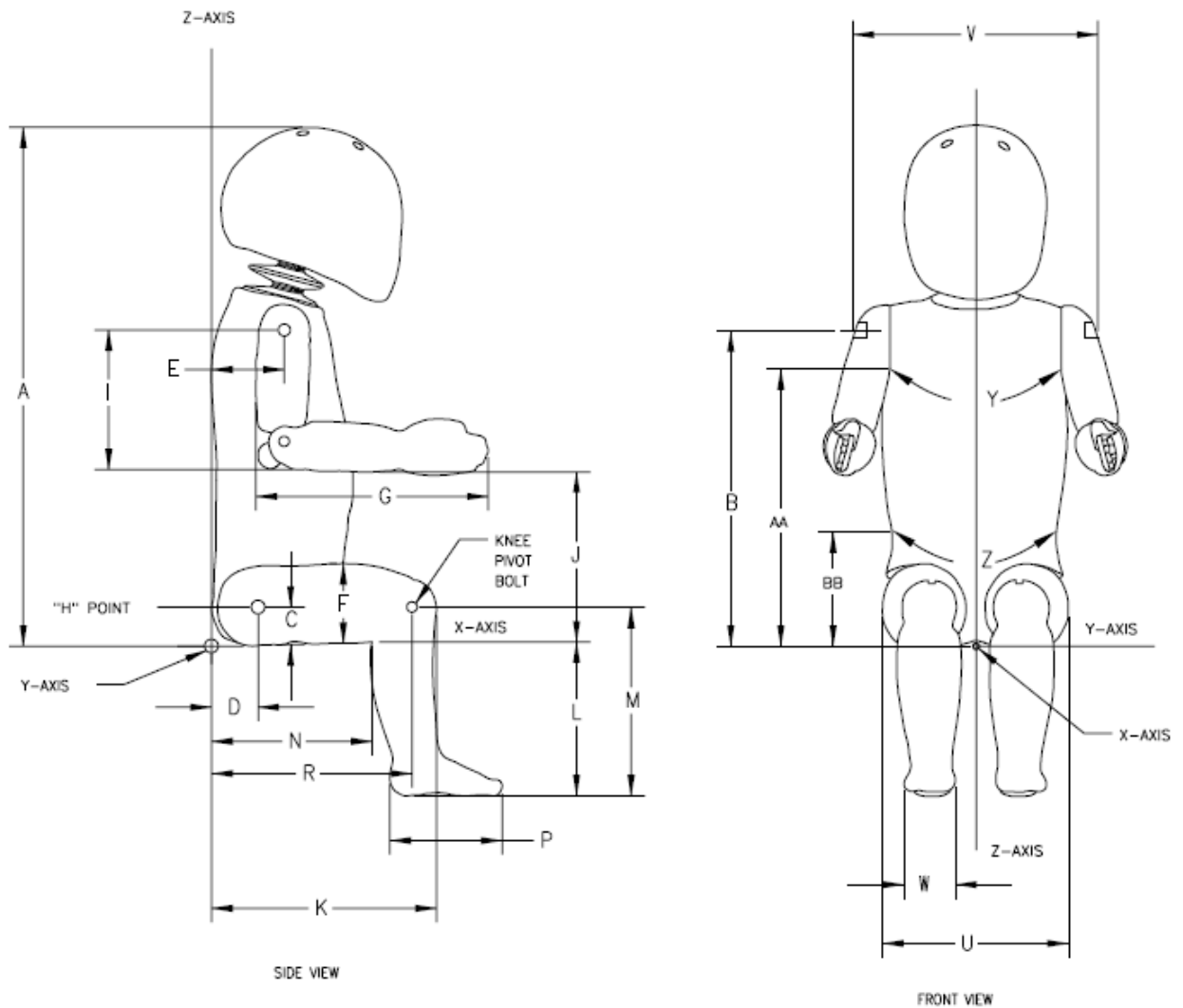

Figure 17. External Dimensions Set-up

5.2 Mass Measurements

1. Check the masses of the various dummy segment assemblies on initial inspection. They should conform to the mass specified in the Table 13 for the twelve-month-old and eighteen-month-old.
2. When replacing components and/or accelerometers, re-check the mass of the pertinent component and/or segment.
3. Head CG location is shown in Appendix E.

Assembly and Part	Part No.	Qty.
Head Assembly (including all parts in Figure 4)		
Head Assembly	921022-001	1
Screw, SHCS #10-32 x 1-1/2 (screw for accelerometer)	9001236	2
Head Accelerometer Assembly with accelerometers and mounts		
Neck Assembly		
Neck Assembly (including all parts in Figure 10)	921022-041	1
Screw, SHCS #10-32 x 1/2	9000147	8
Torso Assembly		
Torso Assembly	921022-060	1
Screw, Modified, SHSS 5/16-1/2 (shoulder)	910420-043	2
Screw, Modified, SHSS 5/16-5/8 (hip)	910420-042	2
Thorax and Pelvis Accelerometer Assembly with accelerometers and mounts		
Complete Arm Assembly (including elbow joint screw)		
Complete Arm Assembly, Left	921022-054L	1
Complete Arm Assembly, Right	921022-054R	1
Complete Leg Assembly (including knee joint screw)		
Complete Leg Assembly, Left	921022-055L	1
Complete Leg Assembly, Right	921022-55R	1

Table 12. Weight and CG

Assembly Weights				
Segment Assembly	Specified Weight			
	12 mo. kg	12 mo. lbs.	18 mo. kg	18 mo. lbs.
Head Assembly	2.64±0.05	5.81±0.11	2.64±0.05	5.81±0.11
Neck Assembly	0.38±0.03	0.84±0.07	0.38±0.03	0.84±0.07
Torso Assembly	3.68±0.10	8.10±0.22	4.45±0.10	9.79±0.22
Arm Assembly	0.60±0.03	1.32±0.07	0.64±0.03	1.41±0.07
Leg Assembly	1.05±0.03	2.31±0.07	1.25±0.03	2.75±1.07
Total Dummy Weight	10.00±0.03	22.00±0.66	11.20±0.30	24.64±0.66

Table 13. Weight Specifications

Section 6. Appendices

6.1 Appendix A

6.1.1 General

The accelerometers used in anthropomorphic test dummies, such as the Hybrid III Dummy Family, are small, low mass piezoresistive accelerometers. Because of their design and inherent mechanics, certain precautions must be observed when handling and mounting accelerometers to avoid damaging them.

When handling and mounting the accelerometer, avoid dropping the accelerometer or striking the unit against hard surfaces. Keep the unit in its protective sleeve until the unit is installed.

6.1.2 Preliminary Check-Out

Before installing any accelerometer into the dummy, check that it operates properly. Three simple tests that require minimal test equipment should be conducted:

1. Impedance test. Read the input impedance (Red to Black) and output impedance (Green to White) with an ohmmeter. Compare the measured values to those on the accelerometer Calibration Data Sheet. The measured impedance should be within +/- 25 percent of the calibrated value.

2. Insulation Resistance. If the input and output impedances are within acceptable limits use a multimeter, ohmmeter, or megohmmeter set at 50 volts maximum. Measure the insulation resistance between:

- all leads connected together and the cable shield.
- all leads connected together and the accelerometer case.
- cable shield and the accelerometer case.

All three readings should be at least 100 megohms. Be careful when connecting 50 VDC to eliminate the possibility of voltage spikes.

3. Zero Measure and Output. After the impedance and insulation resistance tests, measure the output of the accelerometer with zero *g* acceleration. With the unit still in its sleeve, turn the unit on its side so the accelerometer mounting surface is perpendicular to the table top (sensitive axis horizontal and perpendicular to the gravity field). Apply the specified excitation voltage to the accelerometer and measure its output with a DC millivolt meter. Allow the unit to warm-up for two minutes. The accelerometer should have a Zero Measure and Output (ZMO) within the manufacturer's specified limits.

If any of these initial checks do not give proper readings, indicating a possible malfunction, remove the excitation source immediately and take the following measurements.

- Check and record leg 1, leg 2, leg 3, and leg 4 resistances.
- Disconnect, check and record excitation voltage from the source.
- Reconnect, check, and record excitation with the unit connected.

- Check and record ZMO again.
- Check and record static outputs $+1 g$ and $-1 g$ and compare to calibrated sensitivity.
- Check that the temperature and environment fall within accelerometer specification.
- Check to see if the accelerometer case is under stress.
- Check leads for abrasion or cuts.

If the reason for the erroneous reading cannot be found, contact the accelerometer manufacturer.

6.1.3 Installation

When mounting or removing the accelerometer, you must use the proper techniques and tools. The mounting surface should be clean and free of burrs. A recommended surface roughness is 32 micro-inch rms or less. Make sure that no dirt or particles can be clamped between the unit and mounting surfaces.

Remove the unit from the protective sleeve. With the sleeve absent, handle the unit by the case, not the cable. This will prevent the unit from slapping the mounting surface during installation. Place the unit on the mounting surface and align the mounting holes.

Correct torque is important to ensure correct mounting and performance. When mounting the accelerometer, use only the materials and parts which are supplied with the accelerometer. Always use the proper mounting torque recommended by the accelerometer manufacturer. If applicable, use the supplied mounting washers and screws, or mounting stud. Using the supplied wrench, turn the screws into the mounting holes using the recommended torque. Usually, this is roughly equivalent to finger tight with the supplied wrench. Installation of the unit with higher torque values, dry threads, or thread adhesives is not recommended as excessive torque will be required to break the screw loose when the accelerometer is dismounted.

Note:

- Excessive torque can create an over range transient shock pulse, upon removal of the unit, with sufficient high frequency content to damage or destroy the unit.
- Do not over torque the screws.
- Do not use snap type torque wrenches.
- Do not cement the unit to the mounting structure.

Where practical, tie down the cable within 4 to 6 cm (1.6 to 2.4 inches) of the unit. Whipping of the cable during vibration and shock will strain the cable unnecessarily at the unit.

Connect the unit to the signal conditioner and check for proper functioning through the use of standard techniques such as shunt calibration across the passive arms of the accelerometer.

6.1.4 Recalibration

Sensitivity and Zero performed at 6 to 12 month intervals, depending on usage. Usually, 12 month intervals are sufficient if you know the accelerometer has not been used beyond its rated specifications. If the unit is used under severe environments, the shorter calibration interval may be desirable.

6.1.5 Cleaning

Dirty units may be wiped clean using a damp cloth and a solvent such as acetone. DO NOT SOAK OR IMMERSER the unit in any solvent or water. Do not use any sharp tool such as a screwdriver to remove dirt or contaminants. If tools such as pliers are needed to handle the accelerometer, cover the jaws with masking tape to prevent unwanted metal to metal contact.

6.2 Appendix B, Guidelines for Maintenance of Molded Parts

Warning:

Isopropyl alcohol is flammable. Apply only in a well ventilated area.

Unlike other dummies in the Hybrid III family, you should not attempt to repair the flesh of CRABI dummies with a soldering iron. The flesh of the CRABI dummies is made of urethane instead of polyvinyl (PVC).

6.2.1 Flesh Repairs

Minor lacerations to non-critical areas of the dummy's extremities can be repaired with Loctite® 406 (P/N 9001020). Major damages to any of the extremities should be cause to re-skin or replace the parts in question.

If a certain area of flesh is frequently damaged and is not expected to contribute significantly to dummy response, duct tape can be placed on the flesh but under the clothing to help protect it. Tape should not be used on any area which directly affects the test data, such as head or neck. The engineer running the test should approve use of additional reinforcement such as tape before conducting tests.

6.2.2 Storage of Rubber Parts

Spare rubber parts should be stored in a dark location as sunlight and ozone cause the rubber to harden with age. A storage temperature of 18.9 to 25.6 C. is recommended unless the dummy needs to be maintained at a test-ready temperature of 20.6 to 22.2 C.

6.3 Appendix C, Joint Adjustment Procedure

The joints of the CRABI dummies are adjusted to a "1 g suspended setting". This is defined as a torque level on the joint where the friction will allow an assembly to move toward the earth when a small force is applied to the unsupported end of the assembly. For example, when the dummy's arm is fully extended laterally so that it is perpendicular to the body, the shoulder bolt should be tight enough to support the weight of the arm, but loose enough so when you tap the dummy's wrist, the whole arm would slowly fall towards the dummy if friction of the flesh parts did not interfere. The following sections describe how to position the body parts and which joints to tighten to allow a 1 g setting.

6.3.1 Hands and Arms

1. Rotate the complete arm assembly so it points forward and is horizontal. Adjust the shoulder bolts so the arm is suspended at 1 *g*.
2. Position the arm so it points forward and is horizontal. Adjust the elbow pivot bolt through access holes in the lower arm flesh at the elbow to hold the lower arm suspended at 1 *g*.
3. Repeat procedure for other arm.

6.3.2 Legs and Feet

1. With the lower leg at 90° to the upper leg, and the dummy in a seated position, lift the upper leg assembly above horizontal. Adjust the femur bolt so the upper leg is held suspended at 1 *g*.
2. Rotate the lower leg so it is horizontal; adjust the knee clevis bolt so the lower leg is held suspended at 1 *g*.
3. Repeat procedure on other leg.

6.4 Appendix D, Drawings

TE-3200-100 CRABI Neck Test Assembly

TE-3200-110 Weldment, Middle Plate

TE-3200-111 Middle Plate

TE-3200-120 Side Plate, CRABI Head Form

TE-3200-130 Pot Ballast

TE-3200-140 Headform Assembly, CRABI

TE-3200-155 Zeroing Bracket Assembly, CRABI

TE-3200-152 Zeroing Plate II, CRABI

TE-3200-153 Zeroing Plate I, CRABI

TE-3200-160 Adapter Assembly, CRABI Neck Test

TE-3200-161 Adapter, CRABI Neck Test

921022-004 Bushing

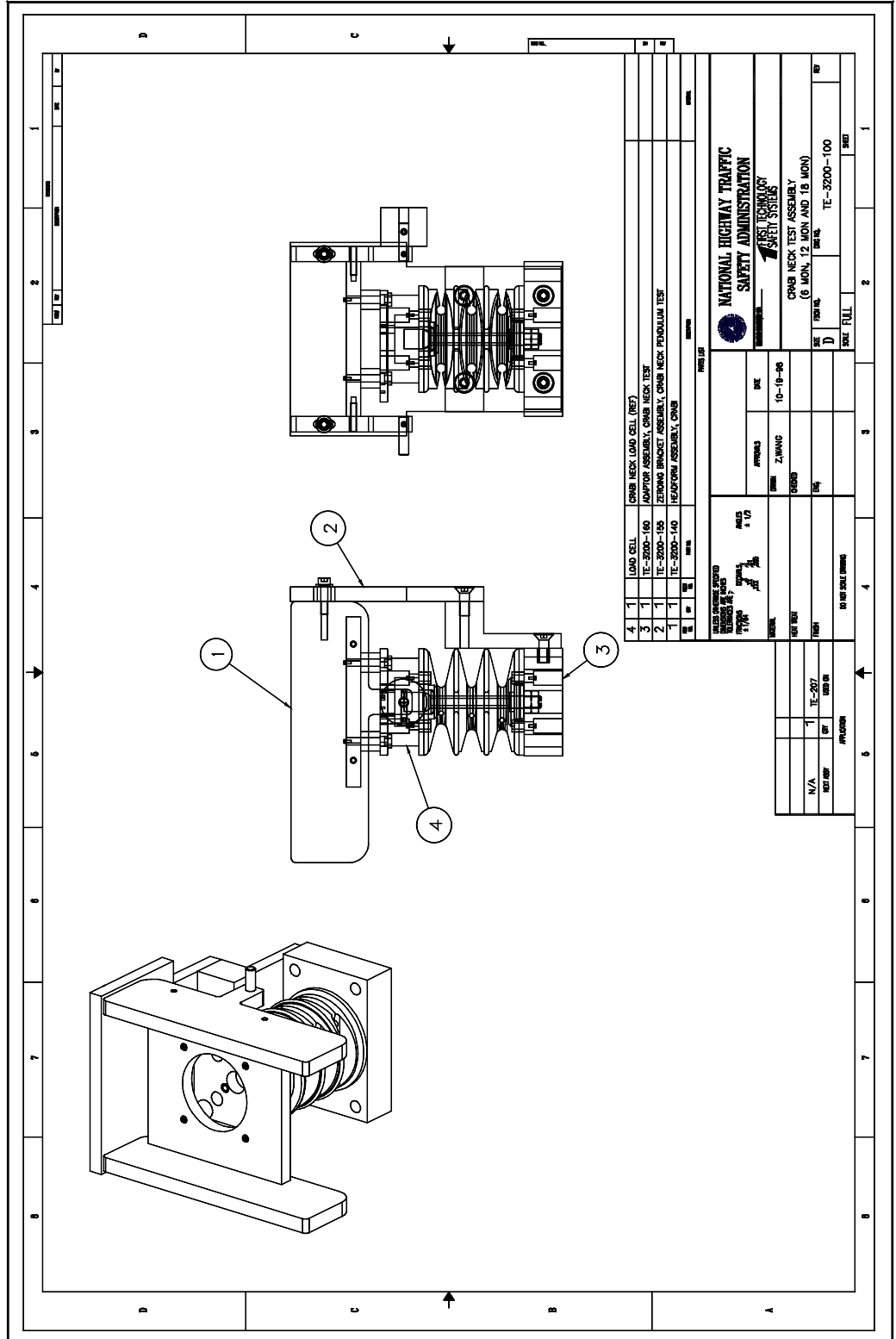

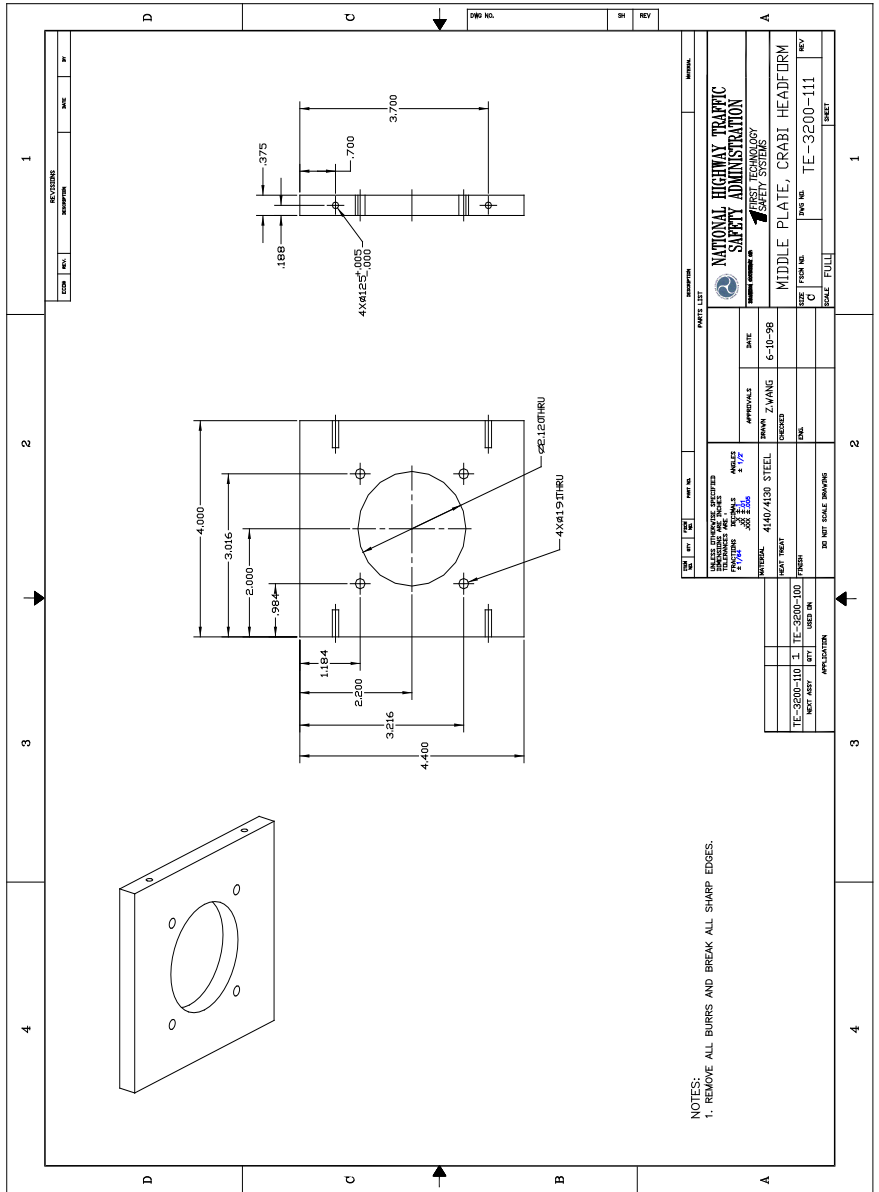

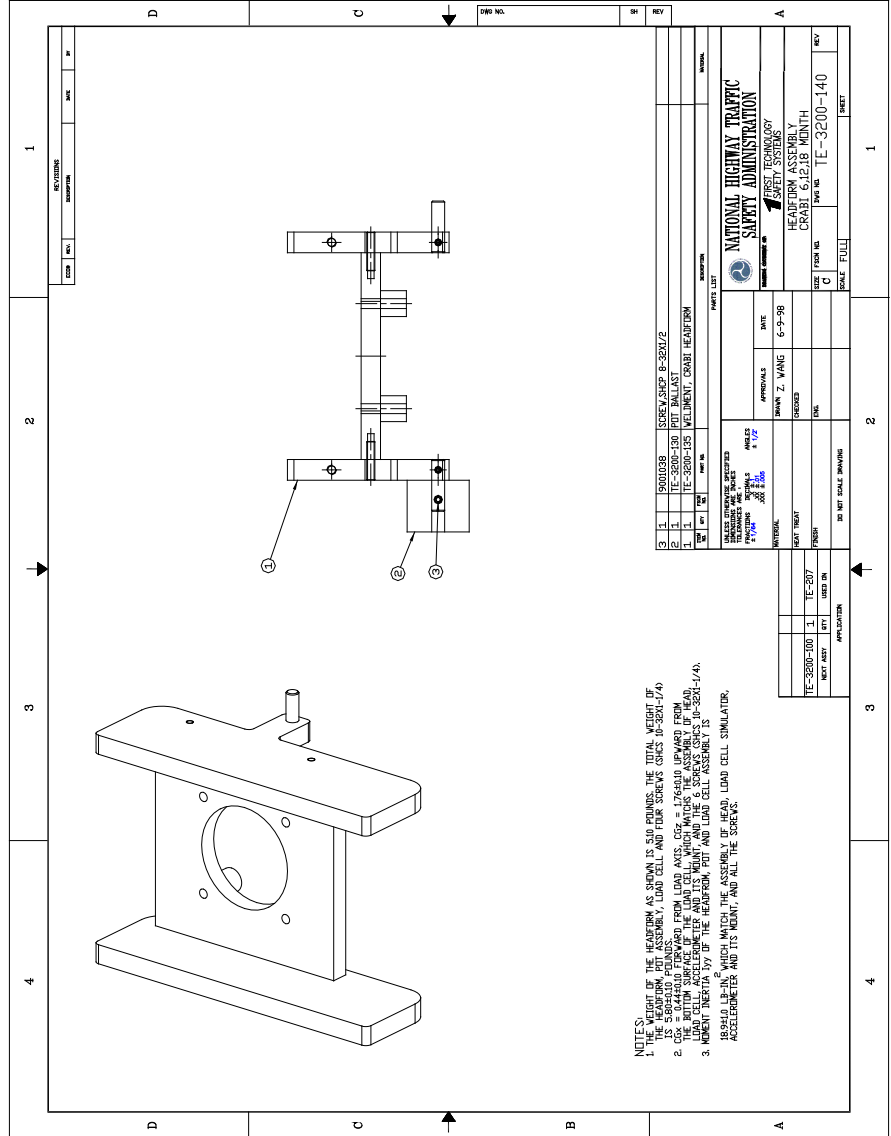

NOTES:
 1. THE WEIGHT OF THE HEADFORM AS SHOWN IS 5.0 POUNDS. THE TOTAL WEIGHT OF THE HEADFORM AND ITS MOUNT, CRABIT ASSEMBLY, LOAD CELL AND FOUR SUREK'S CSK'S IS 5.82410 POUNDS.
 2. USE BOTH SURFACES FOR LOAD MASS. THE CENTER OF MASS IS LOCATED FROM THE CENTER OF THE HEADFORM ASSEMBLY AND ITS MOUNT AND THE 6 SUREK'S CSK'S.
 3. WHEN PARTICIPATING IN THE HEADFORM, FOOT AND LOAD CELL ASSEMBLY IS USED TO MEASURE THE ACCELERATION, ANGULAR VELOCITY, AND THE SUREK'S CSK'S.
 4. THE HEADFORM IS USED IN THE CRABIT ASSEMBLY, LOAD CELL SIMULATOR, AND ITS MOUNT, AND THE SUREK'S CSK'S.

REV	NO	DATE	DESCRIPTION
1	1	10/01/08	ISSUE SPEC P-320/2
2	1	12/01/08	REVISION FOR CRABIT ASSEMBLY
3	1	12/01/08	REVISION FOR CRABIT ASSEMBLY
4	1	12/01/08	REVISION FOR CRABIT ASSEMBLY

REV	NO	DATE	DESCRIPTION
1	1	12/01/08	ISSUE SPEC P-320/2
2	1	12/01/08	REVISION FOR CRABIT ASSEMBLY
3	1	12/01/08	REVISION FOR CRABIT ASSEMBLY
4	1	12/01/08	REVISION FOR CRABIT ASSEMBLY

REV	NO	DATE	DESCRIPTION
1	1	12/01/08	ISSUE SPEC P-320/2
2	1	12/01/08	REVISION FOR CRABIT ASSEMBLY
3	1	12/01/08	REVISION FOR CRABIT ASSEMBLY
4	1	12/01/08	REVISION FOR CRABIT ASSEMBLY

REV	NO	DATE	DESCRIPTION
1	1	12/01/08	ISSUE SPEC P-320/2
2	1	12/01/08	REVISION FOR CRABIT ASSEMBLY
3	1	12/01/08	REVISION FOR CRABIT ASSEMBLY
4	1	12/01/08	REVISION FOR CRABIT ASSEMBLY

REV	NO	DATE	DESCRIPTION
1	1	12/01/08	ISSUE SPEC P-320/2
2	1	12/01/08	REVISION FOR CRABIT ASSEMBLY
3	1	12/01/08	REVISION FOR CRABIT ASSEMBLY
4	1	12/01/08	REVISION FOR CRABIT ASSEMBLY

REV	NO	DATE	DESCRIPTION
1	1	12/01/08	ISSUE SPEC P-320/2
2	1	12/01/08	REVISION FOR CRABIT ASSEMBLY
3	1	12/01/08	REVISION FOR CRABIT ASSEMBLY
4	1	12/01/08	REVISION FOR CRABIT ASSEMBLY

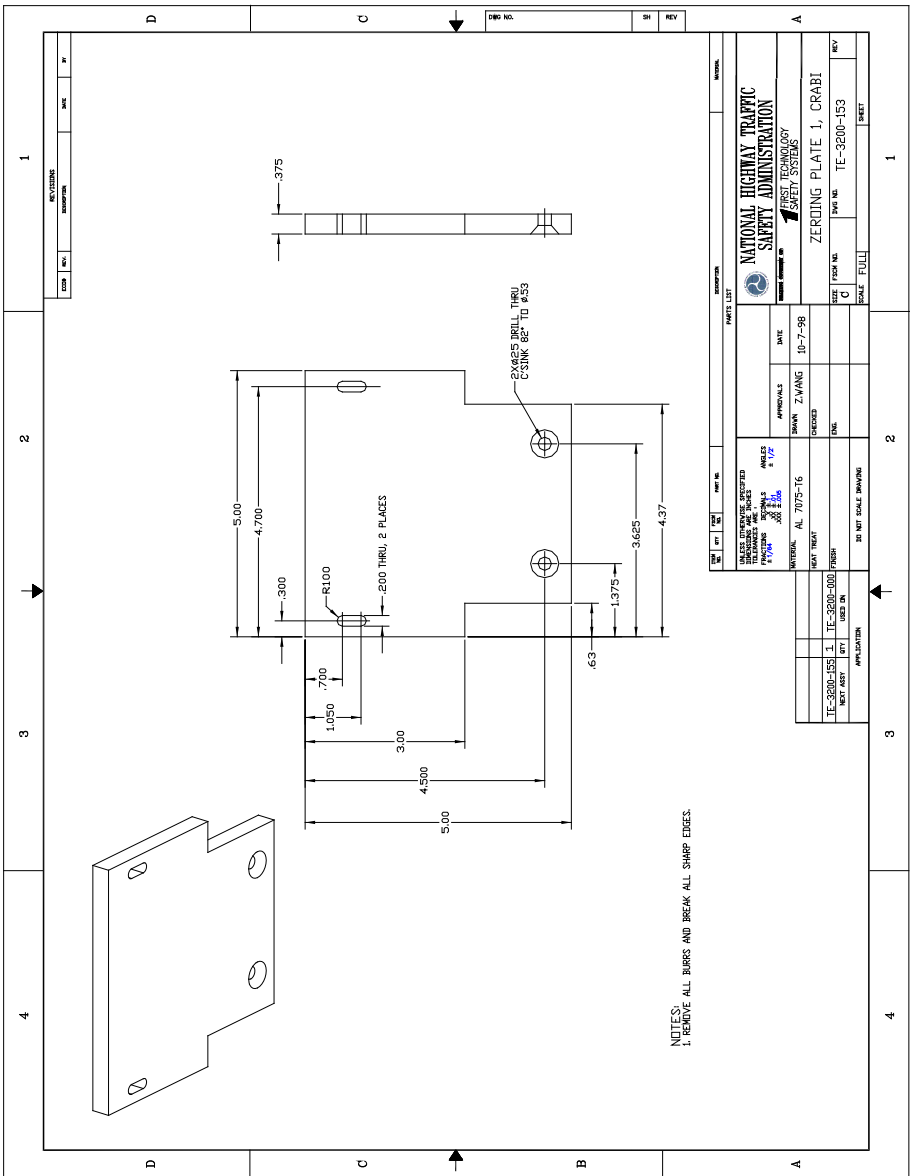

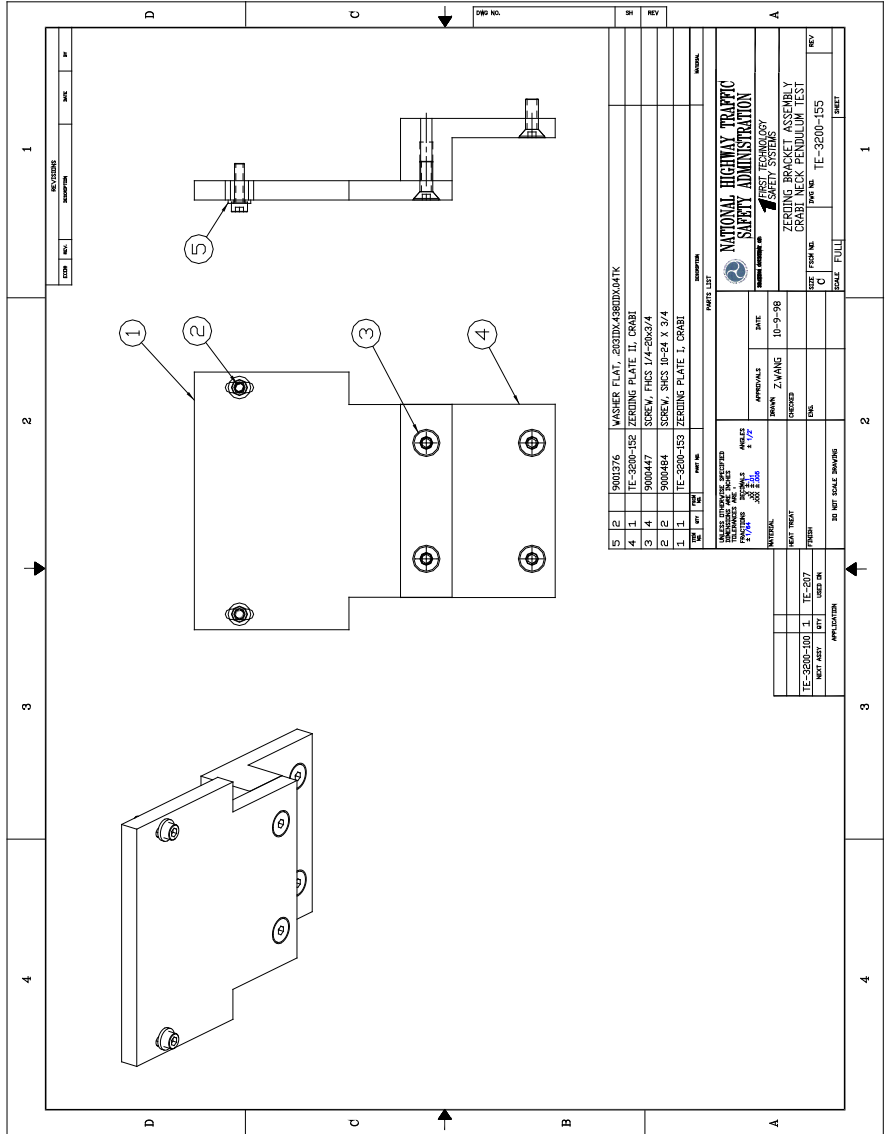

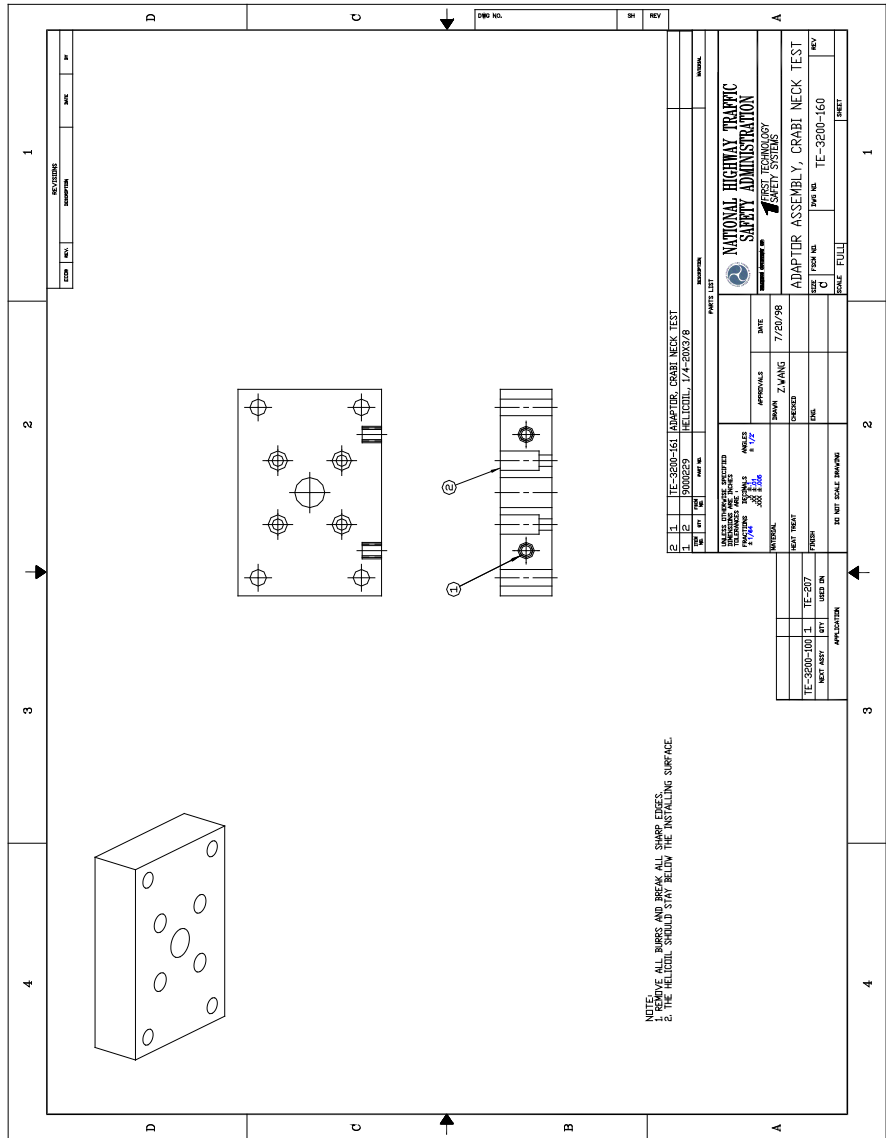

NOTE:
 1. ALL DIMS AND REQS. IN CHAMP. FIGS.
 2. THE HELICAL SHOULD BE PAID BELOW THE INSTALLING SURFACE.

REV	DATE	BY	CHKD	APP'D	DESCRIPTION
1	7/20/98	Z.WANG			ADAPTOR ASSEMBLY, CRABI NECK TEST
2	7/20/98	Z.WANG			ADAPTOR ASSEMBLY, CRABI NECK TEST

TE-3200-100-1	TE-3207	TE-3200-160
TEST ASSEMBLY	USED IN	TEST ASSEMBLY

NATIONAL HIGHWAY TRAFFIC SAFETY ADMINISTRATION
 SAFETY TECHNOLOGY
 ADAPTOR ASSEMBLY, CRABI NECK TEST
 SCALE: FULL

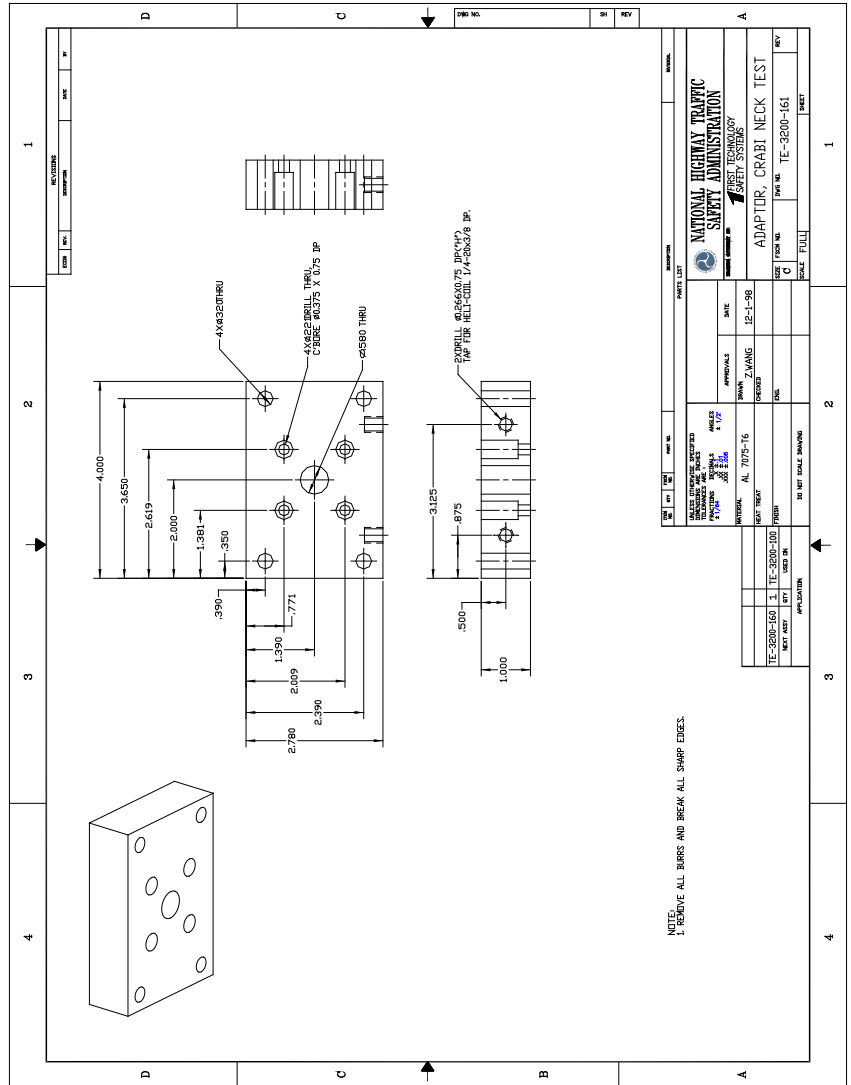

PARTS LIST		REV	
QTY	DESC	DATE	BY
1	PLATE	12-1-98	Y. HANG
1	ADAPTOR, CRABI NECK TEST		
1	TE-3200-161		

APPROVALS		DATE	
DESIGNED BY	Y. HANG	12-1-98	
CHECKED BY			
DATE			
BY			
DATE			
BY			
DATE			
BY			

6.5 Appendix E, Head CG

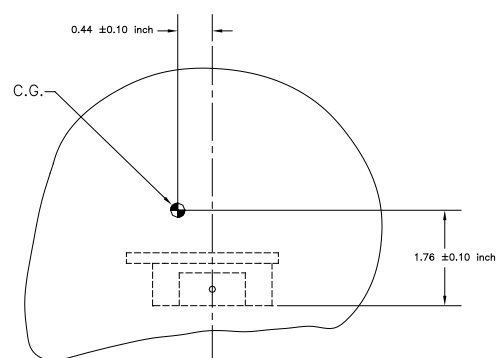

Manual Update Log

Rev. B, Nov. 2011

Manual changed from FTSS to Humanetics

Rev. C, Jul. 2015

Page 2: Added lead material statement