

THOR-50M Standard SBL-B Update

Publication Date: January 2018

Humanetics now offers the THOR-50M Standard Build Level B (SBL-B) incorporating optional enhancements for testing accuracy. Humanetics is now shipping all ATDs at SBL-B and also offers upgrades for previously delivered dummies.

SBL-B Upgrade

The SBL-B upgrade for the THOR-50M ATD is intended to correct a neck cable interference issue, reduce IR-TRACC angularity error, and update Humanetics' certification test corridors.

Upgrading THOR-50M dummies to SBL-B is an optional upgrade meant to enhance the accuracy of the THOR ATD and provide optimum repeatability and reproducibility of test data.

! Backward compatibility of most components is preserved when using replacement SBL-B parts on previous SBL-A dummy builds, but please read each section carefully for details and exceptions.

Neck Upgrade Option

The SBL-B upgrade for the neck has a new front cable assembly that has a slightly shorter threaded end that reduces the risk of interference with the skull plug, thereby eliminating cable bowing and guide damage during testing. Replacing this neck cable on existing SBL-A necks will not automatically ensure conformance to SBL-B test corridors. To ensure passing certification results on existing neck assemblies, the neck rubber certified with new spring and OC stop assemblies may need replacing.

Humanetics offers a certified rubber neck sub-assembly kit (components tested together) that can be used to upgrade existing neck assemblies to the SBL-B design and certification parameters.



Part No.	Description
472-2100-B-KIT	Molded Neck, Tested/Certified, SBL B Kit <i>Includes;</i> 472-2100-B: Neck Molded w/Cables 472-2220: Front Spring Assy 472-2240: Front Spring Assy 472-2230: OC Stop Assy

Note: SBL-A parts kits that are currently on order will be updated with the SBL-B neck cable.

T1 Accelerometer Mount Upgrade Option

The T1 accelerometer mount has been upgraded to include a new alignment pin system to increase mounting accuracy. The original mount relied on a wall interacting with the spine box to prevent rotation, but resulted in a nominal offset from true. The new pin system requires adding dowel pins to the upper thoracic spine box.

! SBL-B replacement mounts will fit onto previous build level spine boxes, but will have no orientation control. Humanetics strongly recommends against this as performance may be critically impaired.

(Continued)

THOR-50M Standard SBL-B Update (Con't)

Thorax IR-TRACC Upgrade Option

The SBL-B Thorax IR-TRACC mountings are upgraded with a new alignment pin system that increases the repeatability of angular positioning and reduces error. The new pin system requires adding dowel pins to the upper thoracic spine box and the LC thoracic spine flex joint adapter assembly.

! SBL-B Thorax IR-TRACC assembly mounts will fit on previous build level spine components without the pin system but will not benefit from the increased mounting precision.

Abdomen IR-TRACC Upgrade Option

The SBL-B Abdomen IR-TRACC mountings are upgraded with a new alignment pin system that increases the repeatability of angular positioning and reduces error. The new pin system requires adding dowel pins to the attachment bracket assemblies. Abdomen brackets are not reworkable parts and must be replaced for SBL-B.

The abdomen IR-TRACC assembly mounts add two pin holes, reducing the number of screws used to mount the IR-TRACCs onto the brackets from 6 to 4.

! SBL-B abdomen IR-TRACC assembly mounts will fit on previous build level abdomen brackets without the pin system but will not benefit from the increased mounting precision. Only 4 screws can be used for mounting.

Note: Because of the rework required for existing thorax spine components, there is no comprehensive Thorax SBL-B parts kit that is offered.

IR-TRACC Set Up Fixture

A new 3D IR-TRACC set up fixture and upgrade kit is available for the upgraded IR-TRACC assemblies with the new mounts.

Molded Shoe Kits

SBL-A Molded Shoe kits will be tested and certified to the new SBL-B corridors.

Upgrade Services

Complete ATDs, including IR-TRACCs, can be returned to Humanetics for the comprehensive upgrade to SBL-B. Re-certification to SBL-B corridors should be done following any upgrade enhancements.

SBL-B upgrades to SBL-A THOR-50M dummies can be performed by Humanetics offices as a service to all worldwide customers.

Upgraded Components

The following pages contain component lists that describe the latest parts and alterations needed to bring standard SBL-A THOR-50M ATDs up to SBL-B.

See also the SBL-A U.S. and Euro NCAP bulletins and the March 2016 Design Change History bulletin for previously updated components.

(Continued)

THOR-50M Standard SBL-B Update (Con't)

STANDARD UPGRADED COMPONENTS

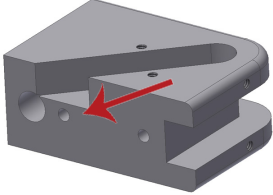
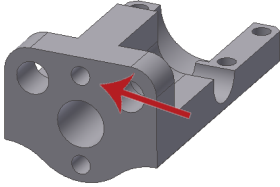
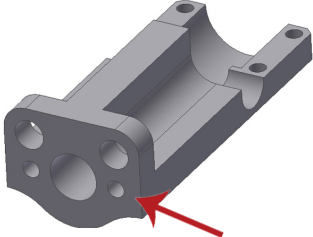
Part Number	Description	Qty Req'd	Comments	
472-2150-B	FRONT CABLE ASSEMBLY, NECK	1	Shorter cable threads. Reduces possible interference with skull plug. Affects head and neck certification.	
AXSDM053-B	T1 ACCELEROMETER MOUNT	2	Added pin holes to increase mounting accuracy.	
472-3551-B*	UPPER THORAX IR-TRACC MOUNT	2	New pin system to reduce angularity error. Two vertical pins to avoid countersunk hole on the upper spine box.	
472-3571-B*	LOWER THORAX IR-TRACC MOUNT	2	New pin system to reduce angularity error. The horizontal pin design allows for wider spacing, improving accuracy.	

* Current SBL-A Parts can be modified

(Continued)

THOR-50M Standard SBL-B Update (Con't)

STANDARD UPGRADED COMPONENTS (Con't)

Part Number	Description	Qty Req'd	Comments
-------------	-------------	-----------	----------

472-4741-B	ABDOMEN IR-TRACC MOUNT	2	New pin system to reduce angularity error.
------------	------------------------	---	--

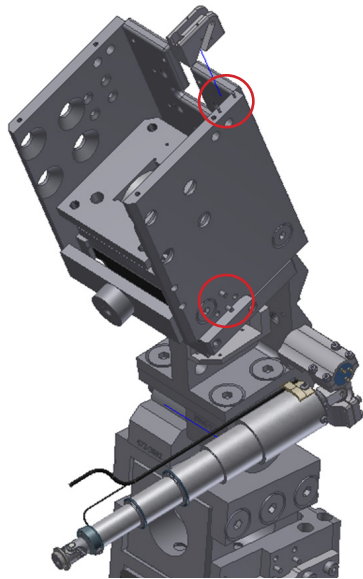
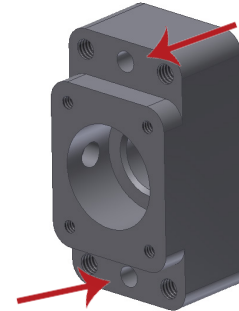

472-3620-B*: Upper Thoracic Spine box weldment with pins at top for updated T1 accel mount and pins on both sides for left and right upper thoracic IR-TRACCs

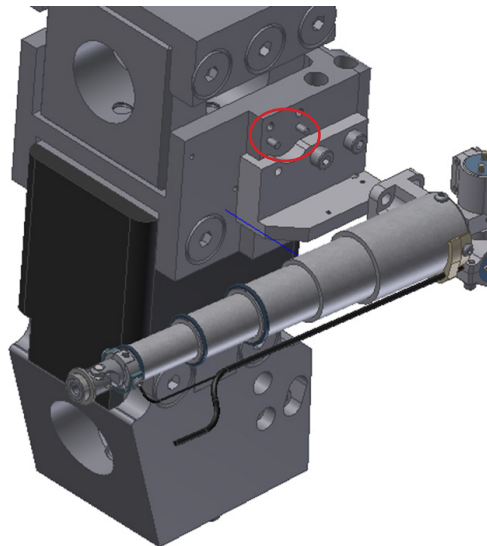

472-3733-B*: LC Thoracic Spine Flex Joint Adapter Assembly with pins on both sides for left and right lower thoracic IR-TRACCs

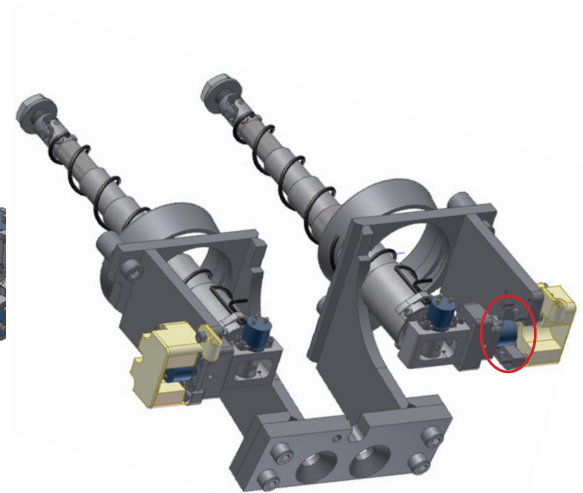

472-4720-1-B, 472-4720-2-B & 472-4721-B: Attachment Bracket Weldment Assemblies Left and Right with pins on both parts for left and right abdomen IR-TRACCs, DGSP mount

* Current SBL-A Parts can be modified

(Continued)

THOR-50M Standard SBL-B Update (Con't)

3D IR-TRACC set up fixture

Part Number	Description	Qty Req'd	Comments
TF-472-6000-B-PR	THOR 3D IRTRACC SET UP FIXTURE	1	New baseplate with locating pins for the upgraded lower thorax IR-TRACC, and new spacer blocks with locating pins for the upgraded upper thorax and abdomen IR-TRACCs
TF-472-6000-B-KIT-PR	THOR 3D IRTRACC SET UP FIXTURE UPGRADE KIT (for existing fixtures)	1	

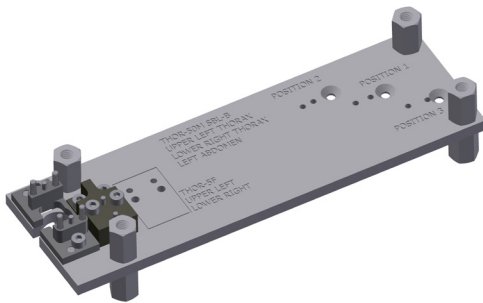

TF-472-6000-B-KIT-PR



TF-472-6000-B-PR

THOR-50M Standard SBL-B Update (Con't)

Testing Summary Comparison

HEAD IMPACT Test Parameter	Units	SBL-A		+/- % Width	SBL-B		+/- % Width	% Mean Shift
		Low Limit	Up Limit		Low Limit	Up Limit		
Velocity	m/s	1.95	2.05	2.5%	1.95	2.05	2.5%	0%
Peak Probe Force	N	5362	5972	5.4%	5100	6234	10.0%	0%
Peak Head CG Resultant Acceleration	g	109.6	124.2	6.2%	105.2	128.6	10.0%	0%
FACE WITH DISK IMPACT Test Parameter								
Velocity	m/s	6.68	6.78	0.7%	6.68	6.78	0.7%	0%
Peak Probe Force	N	6200	7580	10.0%	6376	7793	10.0%	3%
Peak Head CG Resultant Acceleration	g	119	145	9.8%	124	152	10.1%	5%
NECK EXTENSION Test Parameter								
Velocity	m/s	4.95	5.05	1.0%	4.95	5.05	1.0%	0%
Pendulum Velocity @ 10ms after T0	m/s	1.72	1.95	6.3%	1.66	2.03	10.0%	1%
Pendulum Velocity @ 20ms after T0	m/s	3.41	3.84	5.9%	3.23	3.95	10.0%	-1%
Pendulum Velocity @ 30ms after T0	m/s	4.74	5.34	6.0%	4.45	5.44	10.0%	-2%
Peak Head Rotation	deg	55.5	67.9	10.0%	57.9	70.8	10.0%	4%
Peak Upper Neck Fx	N	653	799		-	-		
Peak Upper Neck My	Nm	-22.3	-18.3	9.9%	-25.3	-20.7	10.0%	13%
Peak Upper Neck Fz	N	-3229	-2663	9.6%	-3210	-2627	10.0%	-1%
Peak Anterior Neck Cable Fz	N	2366	2839		-	-		
Peak Head Angular Velocity	deg/s	1867	2224	8.7%	1855	2267	10.0%	1%
Decay Time to 0 Deg. from Peak Angle	msec	69.2	82		-	-		
NECK FLEXION Test Parameter								
Velocity	m/s	4.95	5.05	1.0%	4.95	5.05	1.0%	0%
Pendulum Velocity @ 8 ms after T0	m/s	1.49	1.85	10.8%	1.50	1.83	9.9%	0%
Pendulum Velocity @ 16 ms after T0	m/s	3.08	3.86	11.2%	3.06	3.74	10.0%	-2%
Pendulum Velocity @ 24 ms after T0	m/s	4.48	5.26	8.0%	4.36	5.33	10.0%	-1%
Peak Head Rotation	deg	-69.6	-61.5	6.2%	-70.9	-58.0	10.0%	-2%
Peak Upper Neck Fx	N	-1262	-1081		-	-		
Peak Upper Neck My	Nm	26.2	30.4	7.4%	27.8	34.0	10.0%	9%
Maximum Upper Neck Fz	N	-	-		773	945		
Peak Upper Neck Fz	N	1027	1256		-	-		
Posterior Neck Cable Fz first peak before 60.0ms	N	1003	1226		-	-		
Peak Head Angular Velocity	deg/s	-1933	-1783	4.0%	-2172	-1777	10.0%	6%
Decay Time to 0 Deg. from Peak Angle	msec	81.8	92.1		-	-		

THOR-50M Standard SBL-B Update (Con't)

Testing Summary Comparison

NECK LATERAL (L&R) Test Parameter	Units	SBL-A		+/- % Width	SBL-B		+/- % Width	% Mean Shift
		Low Limit	Up Limit		Low Limit	Up Limit		
Velocity	m/s	3.35	3.45	1.5%	3.35	3.45	1.5%	0%
Pendulum Velocity @ 4ms after T0	m/s	0.90	1.07	8.6%	0.90	1.10	10.0%	2%
Pendulum Velocity @ 8ms after T0	m/s	2.00	2.40	9.1%	1.97	2.40	9.8%	-1%
Pendulum Velocity @ 12ms after T0	m/s	3.03	3.64	9.1%	2.96	3.62	10.0%	-1%
Peak Head Rotation	deg	40.7	44.1	4.0%	-45.9	-37.6	9.9%	-2%
Upper Neck Mx First Peak After 40ms	Nm	41	50.2	9.9%	44.8	54.7	9.9%	9%
Peak Head Angular Velocity	deg/s	1343	1421	0.0%	-1500	-1227	0.0%	-1%
Decay Time to Zero Deg. from Peak Angle	msec	75	84.8		-	-		
NECK TORSION (L&R) Test Parameter								
Velocity	m/s	4.95	5.05	1.0%	4.95	5.05	1.0%	0%
Pendulum Velocity @ 10ms after T0	m/s	1.72	1.98	7.0%	1.62	1.99	10.2%	-2%
Pendulum Velocity @ 15ms after T0	m/s	2.67	2.97	5.3%	2.51	3.07	10.0%	-1%
Pendulum Velocity @ 20ms after T0	m/s	3.59	3.98	5.2%	3.39	4.15	10.1%	0%
Pendulum Velocity @ 25ms after T0	m/s	4.43	4.92	5.2%	4.21	5.14	9.9%	0%
Peak Upper Neck Mz	Nm	38.4	40.7	2.9%	37.3	45.6	10.0%	5%
Peak Neck Fixture Rotation	deg	49.4	52.4	2.9%	43.1	52.7	10.0%	-6%
Peak Upper Neck Angular Velocity	deg/s	1441	1524	2.8%	-1531	-1252	10.0%	-6%
Decay Time to Zero Deg. from Peak Angle	msec	56.3	59.2		-	-		
UPPER THORAX IMPACT Test Parameter								
Velocity	m/s	4.25	4.35	1.2%	4.25	4.35	1.2%	0%
Peak Probe Force	N	2449	2855		N/A	2917		
Peak Upper Left X-Axis Deflection	mm	-46.4	-38.0		-	-		
Peak Upper Right X-Axis Deflection	mm	-46.4	-38.0		-	-		
Difference Betwn Peak L&R X-Axis Defl.	mm	N/A	<7.00		-	-		
Peak Upper Left Z-Axis Deflection	mm	26.2	32.0		-	-		
Peak Upper Right Z-Axis Deflection	mm	26.2	32.0		-	-		
Diff Betwn Peak L&R Z-Axis Defl.	mm	N/A	<7.00		-	-		
Peak Upper Left Resultant Deflection	mm	-	-		45.8	56.0		
Peak Upper Right Resultant Deflection	mm	-	-		45.8	56.0		
Diff Betwn Peak L&R Resultant Defl.	mm	-	-		N/A	5.00		

THOR-50M Standard SBL-B Update (Con't)

Testing Summary Comparison

LOWER THORAX (L&R) IMPACT Test Parameter	Units	SBL-A		+/- % Width	SBL-B		+/- % Width	% Mean Shift
		Low Limit	Up Limit		Low Limit	Up Limit		
Velocity	m/s	4.25	4.35	1.2%	4.25	4.35	1.2%	0%
Peak Force	N	-	-		3132	3827		
Peak X-axis Deflection	mm	-55.3	-45.4		-	-		
Probe Force @ time of Peak X-axis Deflection	N	3058	3680		-	-		
Left or Right Resultant Deflection @ Peak Force	mm	-	-		45.8	56.0		
LOWER ABDOMEN IMPACT Test Parameter								
Velocity	m/s	3.25	3.35	1.5%	3.25	3.35	1.5%	0%
Peak Force	N	2746	3078	5.7%	2631	3215	10.0%	0%
Lower Left Abdomen X-Axis Deflection at Time of Peak Force	mm	-92.9	-70.1	14.0%	-91.3	-74.7	10.0%	2%
Lower Right Abdomen X-Axis Deflection at Time of Peak Force	mm	-92.9	-70.1	14.0%	-91.3	-74.7	10.0%	2%
Difference Between L&R X-axis Deflection	mm	N/A	<12.00		N/A	8.00		-33%
UPPER LEG (L&R) IMPACT Test Parameter								
Velocity	m/s	2.55	2.65	1.9%	2.55	2.65	1.9%	0%
Peak Probe Force	N	4278	5093	8.7%	4217	5154	10.0%	0%
Peak Femur Force Fz	N	-3314	-2712	10.0%	-3314	-2712	10.0%	0%
Peak Resultant Acetabulum Force	N	1478	1806	10.0%	1478	1806	10.0%	0%
KNEE SLIDER (L&R) IMPACT Test Parameter								
Velocity	m/s	2.15	2.25	2.3%	2.15	2.25	2.3%	0%
Peak Femur Z-Axis Force	N	-7170	-5866	10.0%	-7167	-5864	10.0%	0%
Knee Deflection @ Peak Femur Force	mm	-20.9	-19.5	3.5%	-22.2	-18.2	9.9%	0%
EVERSION (L&R) IMPACT Test Parameter								
Velocity	m/s	1.9	2.1	5.0%	1.95	2.05	2.5%	0%
Peak Lower Tibia Fz	N	-629	-515	10.0%	514	629	10.1%	0%
Peak Ankle Resistive Moment	Nm	38.8	47.3	9.9%	38.7	47.3	10.0%	0%
Peak Ankle X-Axis Rotation	deg	27.5	31.5	6.8%	26.6	32.5	10.0%	0%
Initial X-Axis Rotation	deg	-0.5	0.5		-0.5	0.5		0%
Initial Y-Axis Rotation	deg	-0.5	0.5		-0.5	0.5		0%
Initial Z-Axis Rotation	deg	-0.5	0.5		-0.5	0.5		0%

THOR-50M Standard SBL-B Update (Con't)

Testing Summary Comparison

INVERSION (L&R) IMPACT Test Parameter	Units	SBL-A		+/- % Width	SBL-B		+/- % Width	% Mean Shift
		Low Limit	Up Limit		Low Limit	Up Limit		
Velocity	m/s	1.9	2.1	5.0%	1.95	2.05	2.5%	0%
Peak Lower Tibia Fz	N	-560	-458	10.0%	454	555	10.0%	-1%
Peak Ankle Resistive Moment	Nm	35.5	43.4	10.0%	35.2	43.0	10.0%	-1%
Peak Ankle X-Axis Rotation	deg	32.7	36.2	5.1%	31.0	37.9	10.0%	0%
Initial X-Axis Rotation	deg	-0.5	0.5		-0.5	0.5		0%
Initial Y-Axis Rotation	deg	-0.5	0.5		-0.5	0.5		0%
Initial Z-Axis Rotation	deg	-0.5	0.5		-0.5	0.5		0%
BALL OF FOOT (L&R) IMPACT Test Parameter								
Velocity	m/s	4.9	5.1	2.0%	4.95	5.05	1.0%	0%
Initial Y-Axis Rotation	deg	-20.5	-19.5		-20.5	-19.5		0%
Initial Z-Axis Rotation	deg	-0.5	0.5		-0.5	0.5		0%
Initial X-Axis Rotation	deg	-0.5	0.5		-0.5	0.5		0%
Peak Lower Tibia Force Fz	N	-3437	-2897	8.5%	-3488	-2854	10.0%	0%
Peak Ankle Resistive Moment	Nm	50.2	61.3	10.0%	49.8	60.8	9.9%	-1%
Peak Y-Axis Rotation	deg	32.5	35.1	3.8%	30.4	37.2	10.1%	0%
HEEL OF FOOT (L&R) IMPACT Test Parameter								
Velocity	m/s	3.9	4.1	2.0%	3.95	4.05	1.0%	0%
Initial Y-Axis Rotation	deg	-0.5	0.5		-0.5	0.5		0%
Initial X-Axis Rotation	deg	-0.5	0.5		-0.5	0.5		0%
Initial Z-Axis Rotation	deg	-0.5	0.5		-0.5	0.5		0%
Peak Lower Tibia Fz	N	-3477	-2845	10.0%	-3478	-2846	10.0%	0%

RMA Re-certifications

It is recommended that all incoming THOR-50Ms sent to Humanetics for re-certification conform to a Standard Build Level B (SBL-B) prior to testing. Dummies may also require additional parts if the ATD is not up to SBL-A*.

**See also SBL-A and March 2016 Design Change History bulletins for previously updated components.*