

# New THOR-50M Molded Shoe

472-7800-1 and 472-7800-2

Publication Date: January 2017

The THOR-50M ATD uses an updated Thor-LX leg design with a single molded shoe bolted to the ankle. The previous LX design used a molded foam foot fitted with a standard Mil-Spec men's shoe.

## Background

The prior Thor-LX used a molded foam foot, rubber insert and a MIL-Spec shoe. Both the molded foam and the Mil-Spec shoe proved to have wide variability in their performance and construction.

Hoping to improve the repeatability and reproducibility of the prototype molded shoe that Humanetics developed for the THOR-M dummy, NHTSA began working with Humanetics in 2013 to develop a molded shoe that met NHTSA's durability and repeatability/reproducibility requirements. The new molded shoe was developed to meet the geometry and response requirements of the previously-defined molded foot but with a MIL-Spec shoe installed. The resulting design (see Figure 1) may differ from what some customers originally received on their THOR-M ATDs

## Improvements

Humanetics has continued to work with NHTSA to develop a better molded shoe that improves upon the durability and matches the biofidelic requirements. With a wider range of samples and testing, a more reproducible and repeatable shoe was soon constructed.

The latest version of the THOR-50M molded shoe has the durability, geometry, mass, and biofidelity ranking expected for the replacement of the foam foot and Mil-Spec shoe. This includes an



increase in the length of the ankle joint area that matches more closely to the original foam foot with Mil-Spec shoe.

The new molded shoe's construction consists of a urethane upper shell with a carbon fiber foot bone resting upon a bonded heel pad and a ball of foot pad encased with a bonded sole (Figure 1).

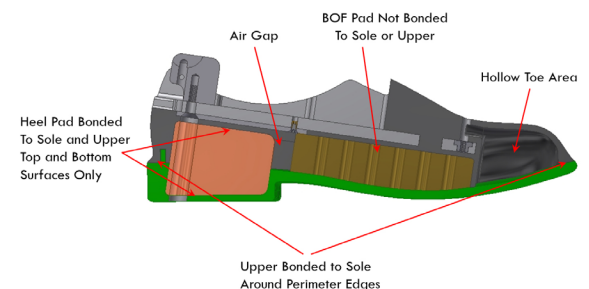

Figure 1 - New Molded Shoe Construction

## Old Molded Shoe vs. New

In addition to the improvements made to the molded shoe, a few parameters have changed. In order to better match with the foam foot and Mil-Spec shoe, the new molded shoe differs from the previous design in the following points:

- The previous molded shoe is approximately 1 inch shorter in height, which makes the overall knee to heel length longer when installing the new version (Figure 2).

(con't)

# New THOR-M Molded Shoe (con't)

## Old Molded Shoe vs. New (Con't)

- The resting angle of the new molded foot bone in relation to the ground is approximately 8.5 degrees, which matches closer to the foam foot and mil-spec shoe. The old molded shoe foot bone is parallel to the ground when resting on the floor.
- New test procedures are required (NQP AUG 2016). \*The tests in the 2015 draft NHTSA Qualifications manual are for use with the foam foot and mil-spec shoe only.

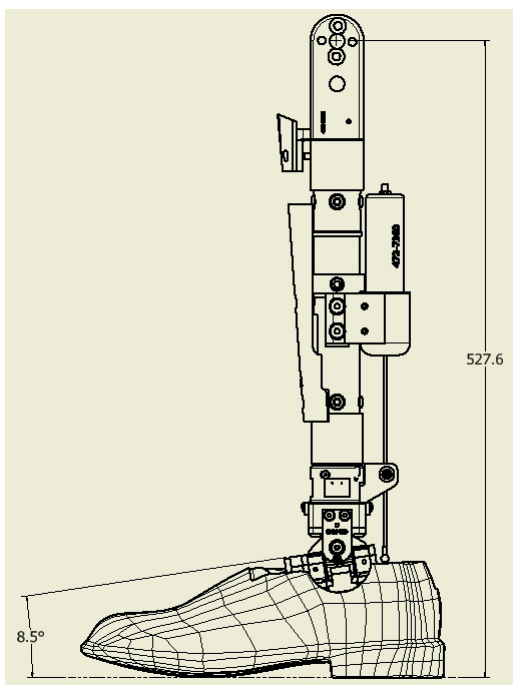

Figure 2 - THOR-LX Leg length and resting angle

## Compliant Bushing and Dorsi-Plantar Stop

In order to certify the leg with the new molded shoe, changes to the compliant bushing and dorsi-plantar stop assembly are required (Figure 3). The stiffness of the compliant bushing in the leg has an effect on the heel of foot performance and the stiffness of the dorsi-plantar stop assembly has an effect on the ball of foot performance.

Complete tibia compliant bushing assemblies can be purchased and replaced in the leg (Figure 4). Existing assemblies can be reworked by removing and replacing the rubber element that is bonded between the flange and plunger that secure it into the leg. Due to the cost of the fixture and labor involved in the rework of the parts, Humanetics offerings a kit that includes the Molded Shoes, Complaint Bushing Assembly and Dorsi Stop Assemblies.

New dorsi-plantar stop assemblies can be removed and bolted directly into place.

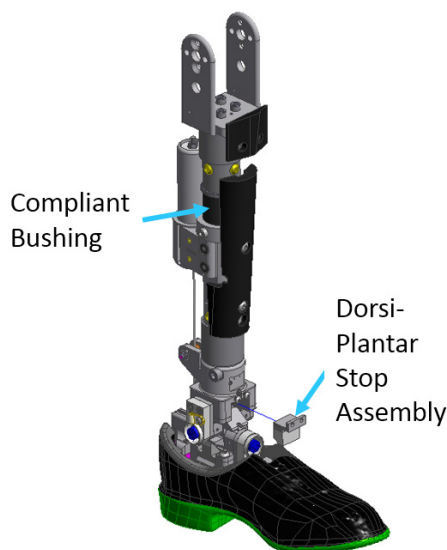

Figure 3 - THOR-LX compliant bushing and dorsi-plantar stop



Figure 4 - THOR-LX tibia compliant bushing assembly

(con't)

# New THOR-M Molded Shoe (con't)

## Current Status

The new molded shoe design has proven to be more durable while meeting biofidelity and testing repeatability requirements. After completing testing evaluations in early 2016, the NHTSA has decided to move forward with the new molded shoe and adopt it into the THOR-LX leg specifications. Humanetics will begin equipping THOR-50M dummies with LX legs with the new shoe beginning early 2017.

## Part Numbers

Part No.	Description	Qty.	Replaces
<b>472-7800-KIT-A</b>	<b>NEW MOLDED SHOE KIT</b> <b>Includes the following:</b>	<b>1</b>	
472-7800-1	MOLDED SHOE ASSY - LEFT	1	472-7740-1-DN
472-7800-2	MOLDED SHOE ASSY - RIGHT	1	472-7740-2-DN
472-7315-A	TIBIA COMPLIANT BUSHING ASSY	2	472-7315-DN
472-7530-DN	DORSI-PLANTER STOP ASSY	2	

For questions please contact your Account Manager or Customer Service Representative.